

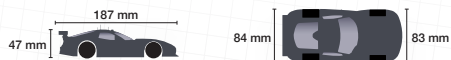

1/24 - 1/32 SLOT CARS & ACCESSORIES

2015 - 2016

SRT Viper GTS-R



ALMS Mid Ohio 2012 #93
SRT Motorsport Team Viper

SC-7055



ALMS Mid Ohio 2012 #91
SRT Motorsport Team Viper

SC-7056



Official Racing Team

SC-7057



	Reference	Motor	Motor Size	Guide	Ratio	Chassis	Ball Bearing	Magnet
ALMS Mid Ohio 2012 #93	SC-7055	SC-26	Long Can	SC-1622	12/44	SC-8000 R4	✓	✓
ALMS Mid Ohio 2012 #91	SC-7056							
Official Racing Team	SC-7057							
Watkins Glen 2014 6h #91	SC-7063							
Watkins Glen 2014 6h #93	SC-7064							
Brickyard GP 2014 Winner	SC-7065							
White body racing kit	SC-7042							

Front		Rear	
ø Tire	Hub	ø Tire	Hub
26 x 10 Hard	23'5 x 10 Aluminum	27 x 13 Soft	23'5 x 13 Aluminum

Ready Painted Bodies	
SC-7055b	ALMS Mid Ohio 2012 #93
SC-7056b	ALMS Mid Ohio 2012 #91
SC-7057b	Official Racing Team #93
SC-7063b	Watkins Glen 2014 6h #91
SC-7064b	Watkins Glen 2014 6h #93

NEW

Watkins Glen 2014 6h #91

SRT Motorsport Team Viper

SC-7063

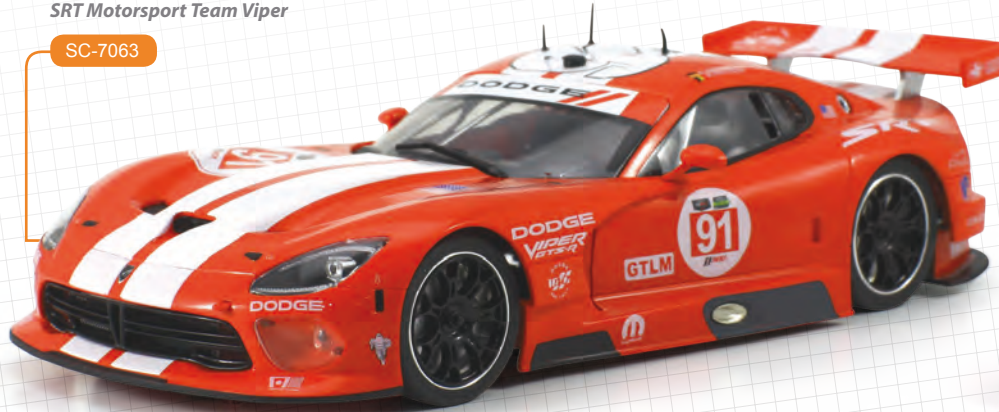
**NEW**

Watkins Glen 2014 6h #93

SRT Motorsport Team Viper

SC-7064

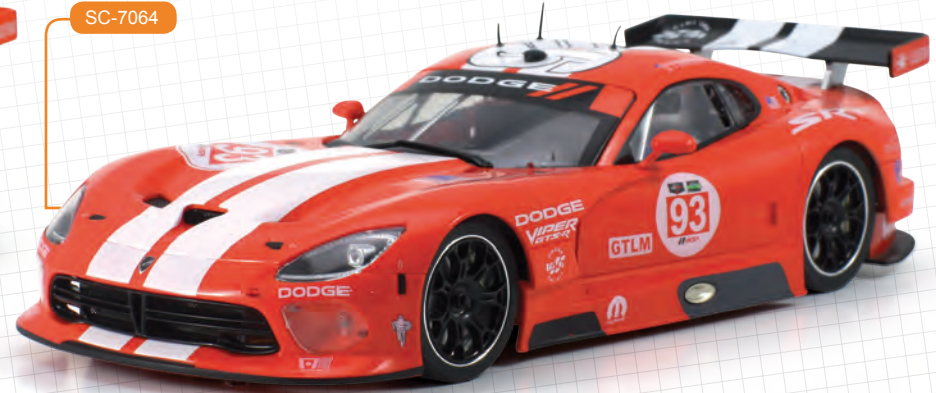
**NEW**

Brickyard GP 2014 Winner #93

SRT Motorsport Team Viper

SC-7065

**Limited
200 pcs.**

Porsche 991 RSR

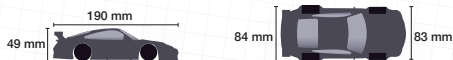

NEW

24h LM 2013 #92 Winner
Porsche AG Team Manthey

SC-7048



NEW

24h LM 2013 #91
Porsche AG Team Manthey

SC-7050



	Reference	Motor	Motor Size	Guide	Ratio	Chassis	Ball Bearing	Magnet
24h LM 2013 #92 Winner	SC-7048	SC-26	 Long Can	SC-1622	12/44	SC-8000 R4	✓	✓
24h LM 2013 #91	SC-7050							
White body racing kit	SC-7047							

Front		Rear	
ø Tire	Hub	ø Tire	Hub
26 x 10 Hard	23'5 x 10 Aluminum	27 x 13 Soft	23'5 x 13 Aluminum

Ready Painted Bodies	
SC-7048b	24h LM 2013 #92 Winner
SC-7050b	24h LM 2013 #91

LMS GT3



24h Nürburgring 2010 #49

Team Alexander Krebs

SC-7053



NEW

24h Spa 2010 #73

W-racing Team

SC-7061



	Reference	Motor	Motor Size	Guide	Ratio	Chassis	Ball Bearing	Magnet
24h Nürburgring 2010 #49	SC-7053	SC-26	 Long Can	SC-1622	12/44	SC-8000 R2		✗
24h Spa 2010 #73	SC-7061					SC-8000 R4	✓	✓
White body racing kit	SC-7044							

Front		Rear	
ø Tire	Hub	ø Tire	Hub
26 x 10 Hard	23'5 x 10 Aluminum	27 x 13 Soft	23'5 x 13 Aluminum

Ready Painted Bodies	
SC-7045b	ADAC Ruhr-Pokal-Rennen 2009 #80
SC-7053b	24h Nürburgring 2010 #49
SC-7054b	ADAC GT masters 2011 #7
SC-7061b	24h Spa 2010 #73

Jaguar XKR GT2

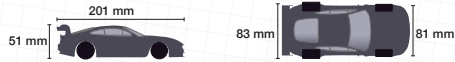

24h LM 2010 #81
Jaguar RSR Racing Team

SC-7023



	Reference	Motor	Motor Size	Guide	Ratio	Chassis	Ball Bearing	Magnet
24h LM 2010 #81	SC-7023	SC-26	Long Can	SC-1601	12/44	SC-8000 R2		

Front		Rear	
ø Tire	Hub	ø Tire	Hub
26 x 10 Hard	23'5 x 10 Aluminum	27 x 13 Soft	23'5 x 13 Aluminum

Ready Painted Bodies	
SC-7023b	24h LM 2010 #81

BMW M3 GT2

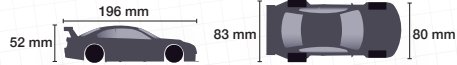

24h LM 2011 #55

Team BMW Motorsport

SC-7035

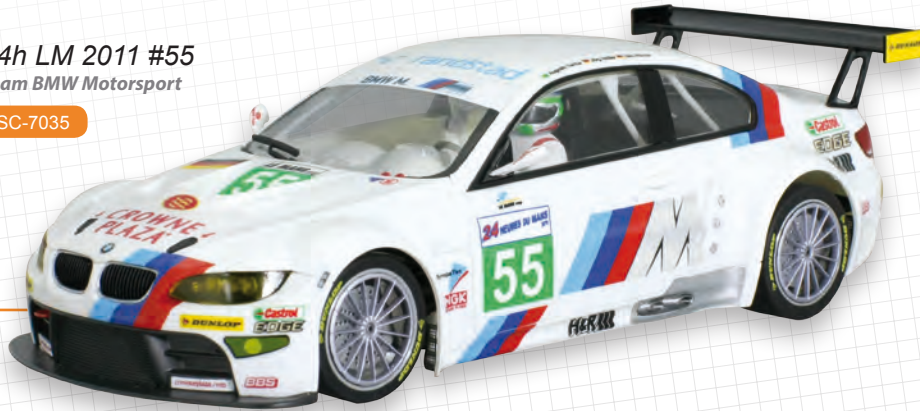

24h LM 2011 #56

Team BMW Motorsport

SC-7036

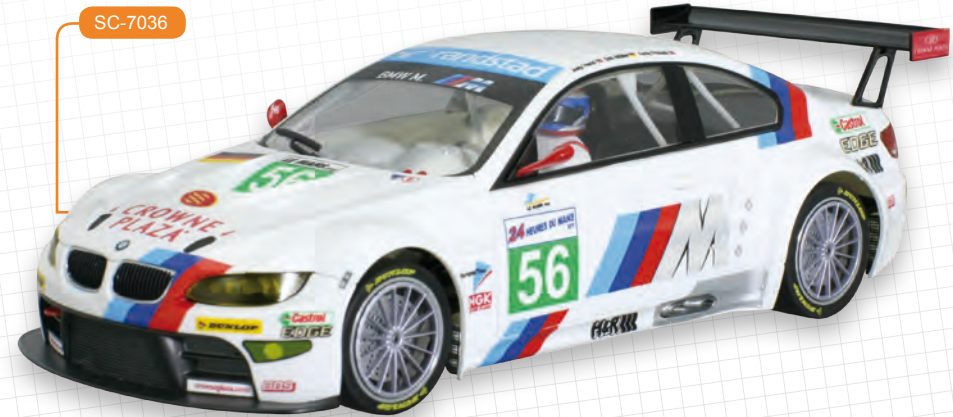



24h Nürburgring 2010

#25 Winner

Team Schnitzer

SC-7022



	Reference	Motor	Motor Size	Guide	Ratio	Chassis	Ball Bearing	Magnet
24h Nürburgring 2012 #25	SC-7022			SC-1624	12/44	SC-8000 R2	✓	✗
24h LM 2011 #55	SC-7035	SC-26		SC-1624	12/44	SC-8000 R2	✓	✗
24h LM 2011 #56	SC-7036							

Front		Rear	
ø Tire	Hub	ø Tire	Hub
26 x 10 Hard	23'5 x 10 Aluminum	27 x 13 Soft	23'5 x 13 Aluminum

Ready Painted Bodies	
SC-7008b	12h Sebring 2009
SC-7015b	24h LM 2010 #78
SC-7017b	24h LM 2010 #79
SC-7022b	24h Nürburgring 2012 #25
SC-7035b	24h LM 2011 #55
SC-7036b	24h LM 2011 #56

BMW Z4 GT3

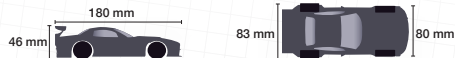

SuperGT 2011 #4
Team Studie AGs

SC-7030



NEW

Silverstone 2011 #40
Winner
Marc VDS Racing Team

SC-7059



	Reference	Motor	Motor Size	Guide	Ratio	Chassis	Ball Bearing	Magnet
SuperGT 2011 #4	SC-7030	SC-26	Long Can	SC-1624	12/44	SC-8000 R2		✗
Silverstone 2011 #40 Winner	SC-7059					SC-8000 R4	✓	✓
VLN Nürburgring 2012 #20	SC-7060					SC-8000 R4	✓	✓
24h Nürburgring 2013 #20	SC-7062					SC-8000 R4	✓	✓
24h Nürburgring 2013 #19	SC-7068					SC-8000 R4	✓	✓
White body racing kit	SC-7031					SC-8000 R2		✗

Front		Rear	
ø Tire	Hub	ø Tire	Hub
26 x 10 Hard	23'5 x 10 Aluminum	27 x 13 Soft	23'5 x 13 Aluminum

Ready Painted Bodies	
SC-7030b	SuperGT 2011 #4
SC-7032b	24h Barcelona 2011 #2
SC-7034b	24h Dubai 2011 #17
SC-7059b	Silverstone 2011 #40 Winner
SC-7060b	VLN Nürburgring 2012 #20
SC-7062b	24h Nürburgring 2013 #20
SC-7068b	24h Nürburgring 2013 #19

NEWVLN Nürburgring 2012 #20
Team Schubert Motorsport

SC-7060

**NEW**24h Nürburgring 2013 #20
Team Schubert Motorsport

SC-7062

**NEW**24h Nürburgring 2013 #19
Team Schubert Motorsport

SC-7068



Porsche 997 RSR

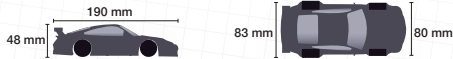

24h LM 2011 #80
Flying Lizard Motorsports

SC-7038



24h LM 2011 #81
Flying Lizard Motorsports

SC-7039



SuperGT 2011 #25
Team Zent

SC-7049



24h LM 2011 #76
Team IMSA Performance

SC-7052



	Reference	Motor	Motor Size	Guide	Ratio	Chassis	Ball Bearing	Magnet
24h LM 2011 #80	SC-7038					SC-8000 R2		X
24h LM 2011 #81	SC-7039					SC-8000 R4	✓	✓
SuperGT 2011 #25	SC-7049	SC-26	Long Can	SC-1622	12/44	SC-8000 R2		X
24h LM 2011 #76	SC-7052							

Front		Rear	
ø Tire	Hub	ø Tire	Hub
26 x 10 Hard	23'5 x 10 Aluminum	27 x 13 Soft	23'5 x 13 Aluminum

Ready Painted Bodies	
SC-7038b	24h LM 2011 #80
SC-7039b	24h LM 2011 #81
SC-7040b	SuperGT 2011 #33
SC-7041b	24h Nürburgring 2011 #25
SC-7049b	SuperGT2011 #25
SC-7052b	24h LM 2011 #76

Porsche 997 GT3 Cup

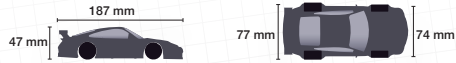

Rally Villajoyosa 2009 #3
Fuster

SC-7012



SC-1605



IMSA 2008 GT3
Challenge #97
Kelly Moss Racing

SC-7013



IMSA 2011 GT3 Cup
Road Atlanta #24
NGT Motorsport

SC-7033



	Reference	Motor	Motor Size	Guide	Ratio	Chassis	Ball Bearing	Magnet
Rally Villajoyosa 2009 #3	SC-7012	SC-25		SC-1605		SC-8000		
IMSA 2008 GT3 Challenge #97	SC-7013				12/44	SC-8000 R2	✓	✗
IMSA 2011 GT3 Cup Road Atlanta #24	SC-7033	SC-26	Long Can	SC-1622				

Front		Rear	
ø Tire	Hub	ø Tire	Hub
26 x 10 Hard	23'5 x 10 Aluminum	27 x 13 Soft	23'5 x 13 Aluminum

Ready Painted Bodies	
SC-7012b	Rally Villajoyosa 2009 #3
SC-7013b	IMSA 2008 GT3 Challenge #97
SC-7033b	IMSA 2011 GT3 Cup Road Atlanta #24

SLS AMG GT3

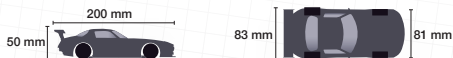

NEW

24h Nürburgring 2012 #66
Heico Motorsport

SC-7026



ADAC GT Master 2011 #32
Gize-SLS Team

SC-7028



VLN Nürburgring 2011 #15
Mamerow Racing Team

SC-7046



	Reference	Motor	Motor Size	Guide	Ratio	Chassis	Ball Bearing	Magnet
24h Nürburgring 2012 #66	SC-7026					SC-8000 R4		✓
ADAC GT Master 2011 #32	SC-7028	SC-26		SC-1622	12/44	SC-8000 R4	✓	✓
VLN Nürburgring 2011 #15	SC-7046		Long Can			SC-8000 R2		✗

Front		Rear	
ø Tire	Hub	ø Tire	Hub
26 x 10 Hard	23'5 x 10 Aluminum	27 x 13 Soft	23'5 x 13 Aluminum

Ready Painted Bodies	
SC-7024b	IberGT Jarama 2011 #23
SC-7026b	24h Nürburgring 2012 #66
SC-7027b	24h Nürburgring 2011 #3
SC-7028b	ADAC GT Master 2011 #32
SC-7046b	VLN Nürburgring 2011 #15

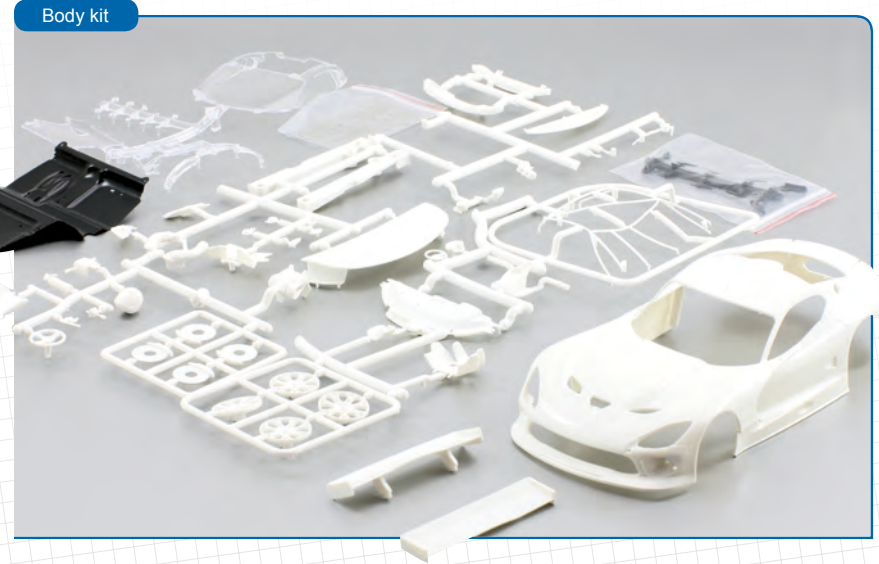
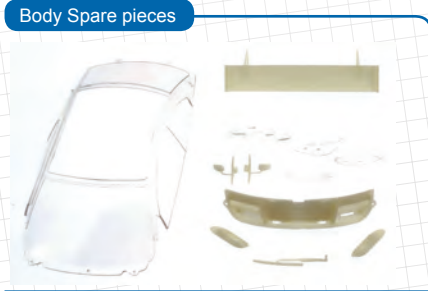

Car Model	Body kit	Body spare pieces	Cockpit	Lightweight kit	Rear wing	Metal body mount
Porsche 911 RSR (911 Model)		SC-7611		SC-7901	SC-7901b	SC-8117
Porsche 911 GT3 (911 Model) Cup & Rally	SC-7502	SC-7611	SC-7604	SC-7901		SC-8117
BMW M3 GT2	SC-7503	SC-7612		SC-7902	SC-7902b	SC-8119
XKR GT2	SC-7504			SC-7903	SC-7903b	SC-8119
Mercedes SLS AMG GT3	SC-7505	SC-7614		SC-7904	SC-7904b	SC-8119
LMS GT3	SC-7506	SC-7616	SC-7605	SC-7905	SC-7905b	SC-8124
BMW Z4 GT3	SC-7507	SC-7617		SC-7906	SC-7906b	SC-8125
SRT Viper GTS-R	SC-7508 NEW			SC-7908	SC-7908b	SC-8131
Porsche 991	SC-7509 NEW			SC-7909	SC-7909b	SC-8139

SC-8000RTR4b

Complete SC-8000 R4 assembled chassis. Fixed guide. With magnet. Sponge tires.

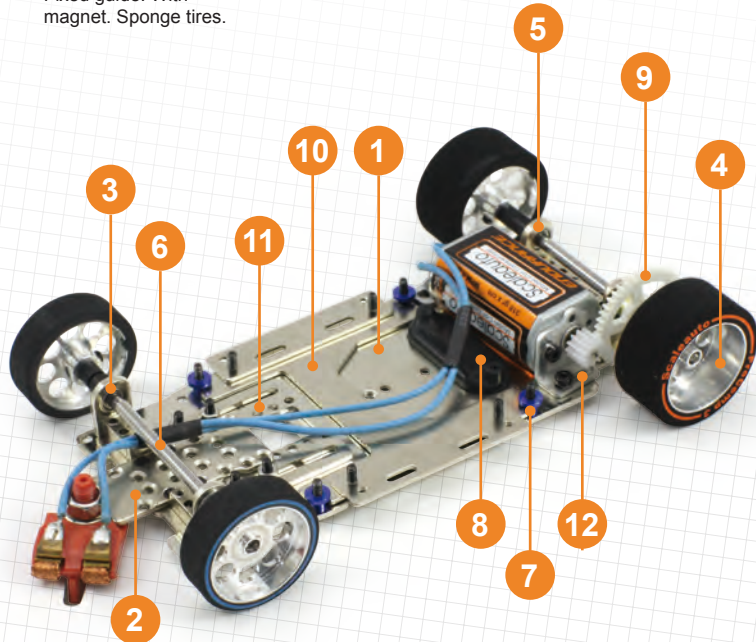

Technical Specifications

1. Stamped quality steel chassis.
2. Front hardened steel guide support adjustable length.
3. Independent axle mounts, fully adjustable height and options.
4. Front and rear wheels with aluminum lightened rim and competition sponge tires.
5. Ball bearings
6. High rotation quality straight axles.
7. CNC aluminum suspension pillars.
8. Magnet for high speed racing or new users. Removable for expert users.
9. Procomp RS3 gear. Adjustable gear ratio.
10. Light aluminum H plate.
11. Front axle steel subframe for adjustable wheelbase.
12. CNC aluminum motor mount.

SC-8000RTR4c

Complete SC-8000 R4 chassis kit. Fixed guide. With magnet.

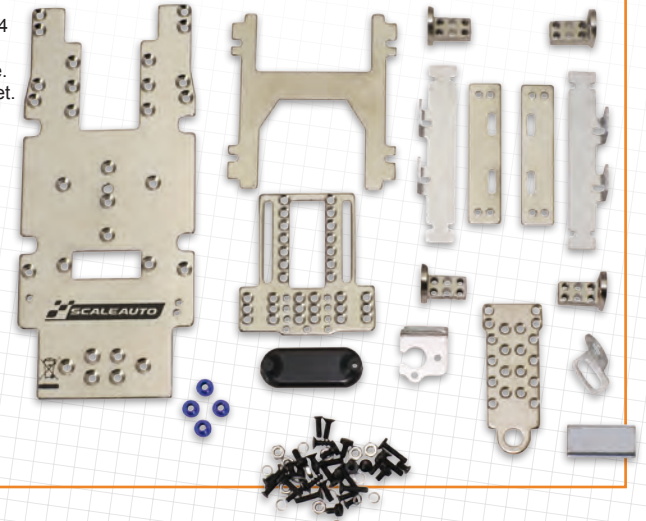

SC-8128

R4 chassis main plate.

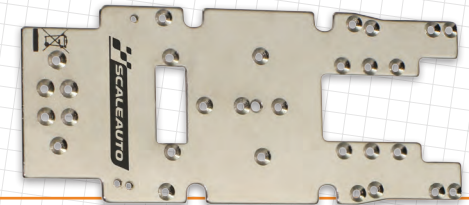

SC-8101

H plate (steel)

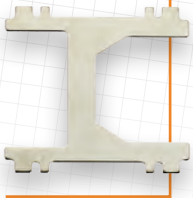

SC-8101al

H plate (aluminum)

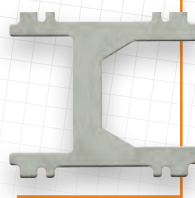

SC-8101c

H plate (carbon fiber)

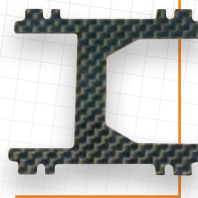

SC-8102c

H plate pro (carbon fiber)

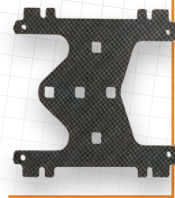

SC-8103

Front axle subframe (steel)

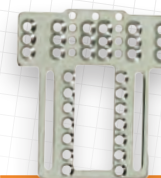

SC-8104

Fix guide holder (steel)



SC-8104c

Fix guide holder (carbon fiber)

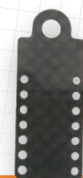

Aluminum body suspension supports

- SC-8126a ● 2mm • blue
- SC-8126b ● 3mm • purple
- SC-8126c ● 4mm • copper
- SC-8126d ● 5mm • black
- SC-8126e ● 6mm • red
- SC-8126f ● 1,5mm • orange
- SC-8126g ● 2,5mm • silver
- SC-8126h ● 3,5mm • light blue
- SC-8126i ● 4,5mm • green



NEW

SC-8111

Steel 3 mm axle spacer.



SC-8112

Plastic 3 mm body spacer.



SC-8113

Steel 2 mm body spacer.



SC-8121

Rear axle mount self adjustable.

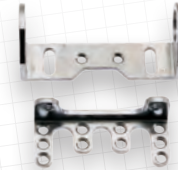

SC-8106

Complete swing arm set for rally setup.



Non concentric

- SC-8145a 2mm
- SC-8145b 3mm
- SC-8145c 4mm
- SC-8145d 5mm
- SC-8145e 6mm
- SC-8145f 1,5mm
- SC-8145g 2,5mm
- SC-8145h 3,5mm
- SC-8145i 4,5mm



NEW

SC-8114

Motor mount. Rev4

SC-8114b

Motor mount CNC. Rev4



SC-8115b

Motor mount can fixing. Rev4



SC-8107

Body mount set.

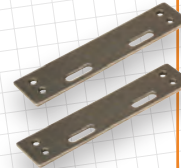

SC-8129

Magnet and magnet holder.



SC-8146

Suspension post adjustment.



Axle mount spacers

- SC-8127d 0,10 mm
- SC-8127e 0,25 mm
- SC-8127f 0,50 mm

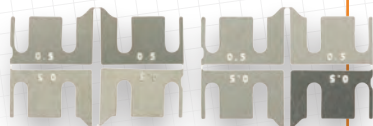

SC-8120

Screw sets for body.

NEW



SC-8122

Screw sets for chassis.

NEW



Axle mounts

Standard

- SC-8108a 7mm
- SC-8108b 8mm
- SC-8108c 9mm
- SC-8108d 10mm
- SC-8108e 11mm



Lightweight

NEW

- SC-8147a 7mm
- SC-8147b 8mm
- SC-8147c 9mm
- SC-8147d 10mm
- SC-8147e 11mm



Suspension system

- SC-8109a 7mm
- SC-8109b 8mm
- SC-8109c 9mm
- SC-8109d 10mm
- SC-8109e 11mm



SC-8001c

NEW

Classic narrow kit

SC-8002c

Classic wide kit

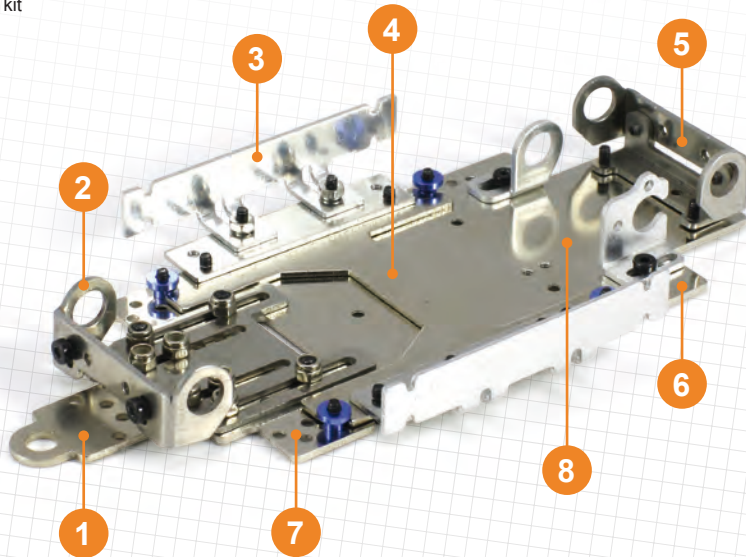

Technical Specifications

1. Adjustable guide length. Compatible with SC-8000 Chassis.
2. Self adjustable front axle heigh system.
3. Aluminum universal body mounts. Compatible with SC-8132 multi adjustable.
4. H plate. Compatible with SC-8000 Chassis. Extended medium size.
5. Self adjustable rear axle mount. Compatible with SC-8000 CNC Aluminum mounts.
6. Motor mount for Small and Large Can motors.
7. Lasercut complete flat chassis frame.
8. Floating motors system SC-8142 for better performance.

SC-8132

Universal body mount

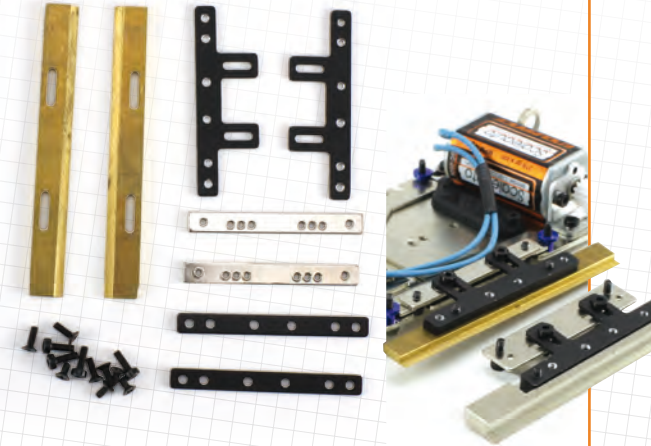

SC-8134a

Body mount spacers
0,25 mm

SC-8134b

Body mount spacers
0,50 mm



Narrow chasis main plates

Steel base

SC-8144a

1,5 mm thick

SC-8144a2

1,2 mm thick

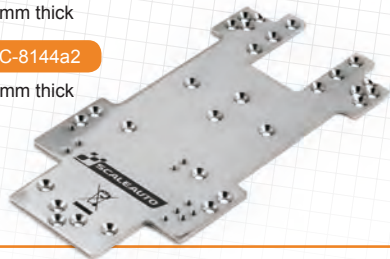

Brass base

SC-8144b

1,5 mm thick



NEW

Wide chasis main plates

Steel base

SC-8148a

1,5 mm thick

SC-8148a2

1,2 mm thick

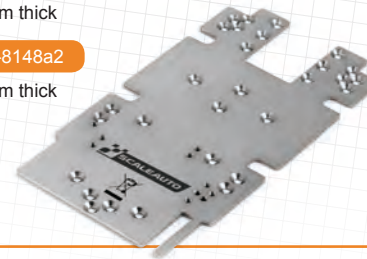

Brass base

SC-8148b

1,5 mm thick

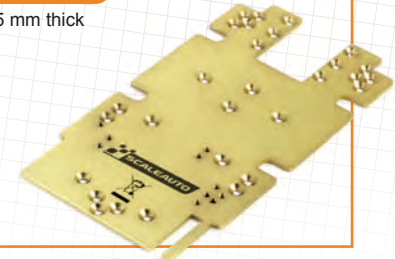

NEW

SC-8141
Axle holder
6 mm.

NEW

SC-8141b
Front axle suport

NEW

SC-8141c
Rear axle suport

NEW

SC-8143a
H plate medium
lenght

NEW

SC-8143b
H plate medium
lenght carbon fiber.

NEW

SC-8151 **NEW**
U shape body mount
adapter, to use with
Sc-8133 CNC body
adapters, or
replacement form
Sc-8132

SC-8136a
Motor mount. Offset 0,0 mm.

SC-8136b
Motor mount. Offset 1,2 mm. *

SC-8136c
Motor mount. Offset 2,7 mm.
Needs hollowed main base
chasis. *

**Requires SC-8142*

SC-8137a **NEW**
Motor mount. Offset 0,0 mm.

SC-8137b
Motor mount. Offset 1,2 mm. *

SC-8137c
Motor mount. Offset 2,7 mm.
Needs hollowed main base
chasis. *

**Requires SC-8142*

SC-8150
Sponge for body
assembly (100 x
120 x 5 mm).

SC-8149
Guide post for
1/32 guides.

CNC Body Mounts

SC-8133a 80 mm x 12 mm

SC-8133b 80 mm x 10 mm

SC-8133c 70 mm x 8 mm

SC-8133d 65mm x 6,5 mm

SC-8142 **NEW**
Subframe motor
mount

SC-8135 **NEW**
Body mount spacers
aluminum

SC-8140 **NEW**
L shape body mount
to use with SC-8107
or SC- 8132



SC-8300b

Chassis SC-SWRC complete assembled with sponge tires.

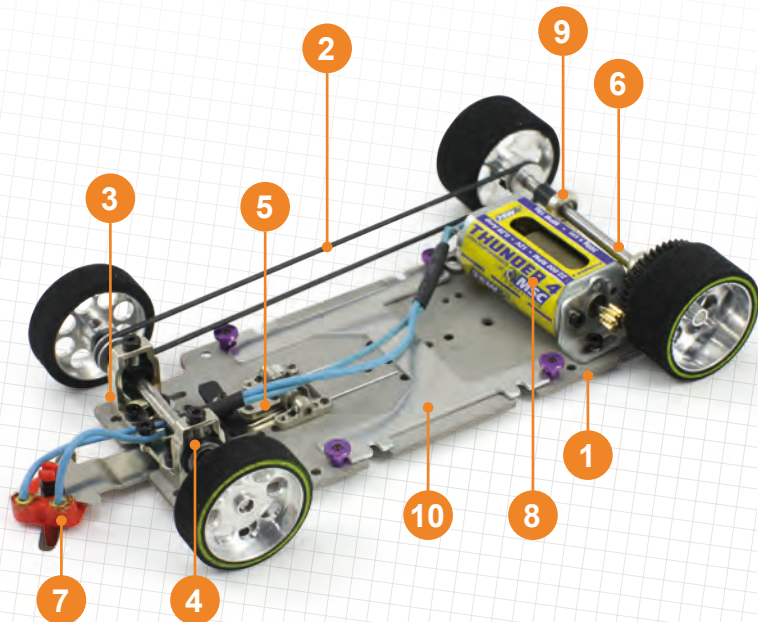

Technical Specifications

1. 1.5 mm thick steel main frame
2. 4x4 system with CNC friction pulley, traction MXL pulley is optional
3. Fully adjustable wheelbase from 93 mm to 111 mm
4. Front axle adjustable in height and spring tension
5. Swing arm system. Fully adjustable angle and distance from front and rear axle
6. Hardened Axles and Ball bearings
7. Useable for plastic and wooden track
8. High torque SC-25 (MSC Thunder 4) motor
9. Adjustable height aluminum body mounts
10. Spares compatible with Scaleauto SC-8000 chassis

SC-8300c

Complete chassis in kit form.

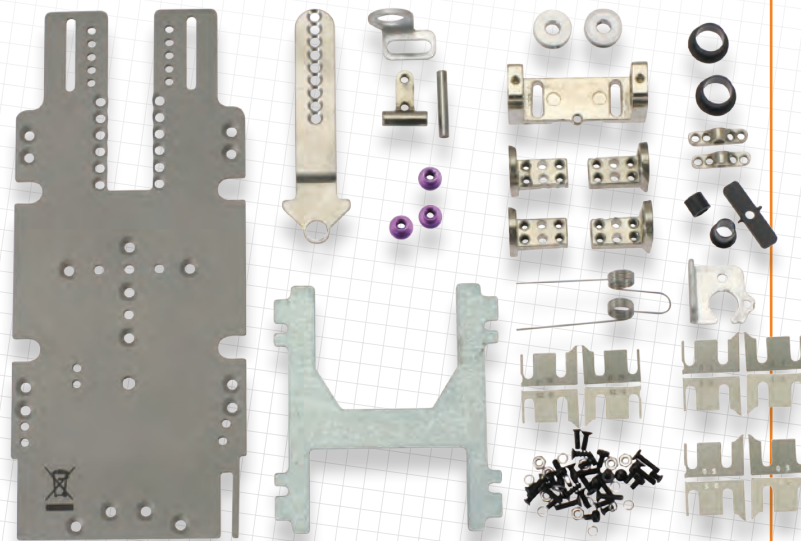

SC-8301

Chassis SC-SWRC main base.

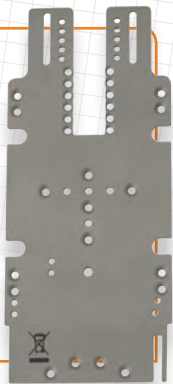

SC-8305

Chasis SC-SWRC H plate large size carbon fiber.

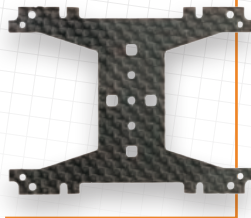

SC-8302

Chassis SC-SWRC complete front axle suspension system and Swing arm.

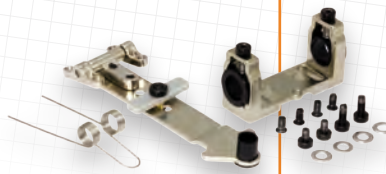

SC-8307a

Axle mount spacer, 0,50 mm.

SC-8307b

Axle mount spacer, 0,25 mm.

SC-8307c

Axle mount spacer, 0,10 mm.

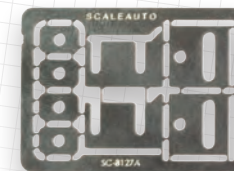

Body mounting sets

Reference	Car Model	Body brand
SC-8304a	Peugeot 207 S2000, including lexan pieces	Belkits
SC-8304b	Citroën DS3 WRC, including lexan pieces	Heller
SC-8304c	Ford Fiesta S2000 & WRC, including lexan pieces	Belkits
SC-8304d	Skoda Fabia S2000, including lexan pieces	Belkits
SC-8304e	Mini Countryman WRC, including lexan pieces. NEW	Hasegawa
SC-8304f	VW Polo R WRC, including lexan pieces. NEW	Belkits

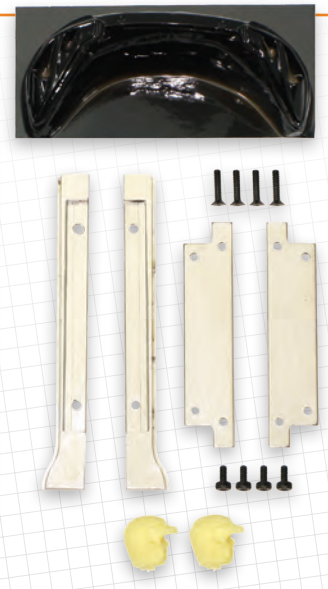
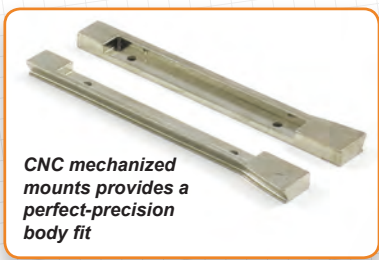

SC-8306 **NEW**

Chasis SC-SWRC H plate height adjustment system.

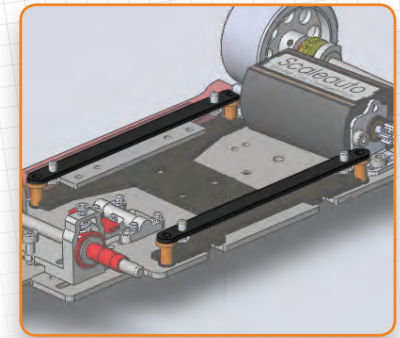
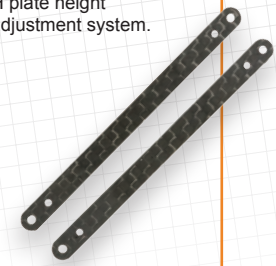

New standard for gear teeth number identification

Scaleauto's gear range is ruled under the new Color Code that states a unique color to each gear depending on the amount of teeth. Standardisation makes tuning experience smoother for the serious Professional Slot Racer.

Color / Gear teeth
20 / 30 / 40
21 / 31 / 41
22 / 32 / 42
23 / 33 / 43
24 / 34 / 44
25 / 35 / 45
26 / 36 / 46
27 / 37 / 47
28 / 38 / 48
29 / 39 / 49

SC-1126
Axle stopper 3 mm
light and anodized.
M3 screw.



NEW Improved with new aluminum hardened insert.



IN-LINE RS (3 mm)				
	Reference	Color	Teeth	∅
	SC-1102		32	∅ 17,25 mm
	SC-1104		34	∅ 18,35 mm
	SC-1105		35	∅ 18,9 mm
NEW	SC-1106		36	∅ 19,5 mm
	SC-1107		37	∅ 20,0 mm
NEW	SC-1108		38	∅ 20,5 mm

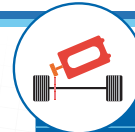

ANGLEWINDER RS-3 (3 mm)				
	Reference	Color	Teeth	∅
NEW	SC-1048b		36	∅ 19,0 mm
NEW	SC-1049b		37	∅ 19,5 mm
NEW	SC-1050b		38	∅ 20,0 mm
NEW	SC-1051b		39	∅ 20,5 mm
	SC-1052b		40	∅ 21,0 mm
	SC-1053b		41	∅ 21,5 mm
	SC-1054b		42	∅ 22,0 mm
	SC-1055b		43	∅ 22,5 mm
	SC-1056b		44	∅ 23,0 mm
	SC-1057b		45	∅ 23,5 mm
NEW	SC-1058b		46	∅ 24,0 mm

SC-1601

Pro guide 3/16" club
8,5 mm blade.

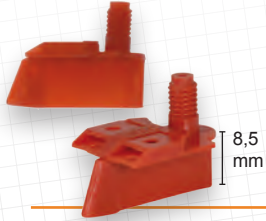

SC-1624

Narrow pro guide 3/16"
club racing
9,1 mm blade.

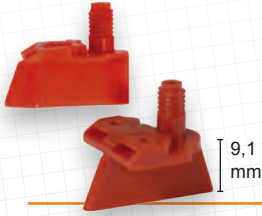

Universal Soft Braids

SC-1614 6 units.

SC-1614b 50 units.

SC-1614c 100 units.

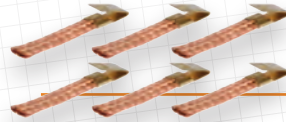

Narrow Braids

SC-1628 6 units.

SC-1628b 50 units.

SC-1628c 100 units.

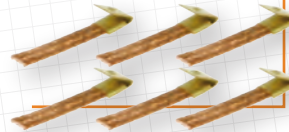

SC-1632

Super slim braids with
clips for 3/16".

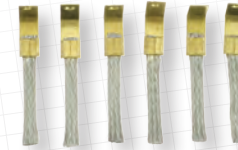

SC-1637

NEW

Standard braid clips
(10 units)

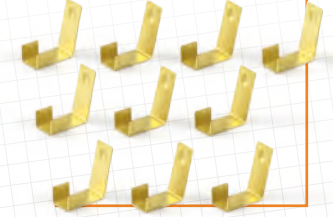

SC-1602

Pro guide 3/16" home
7 mm blade.

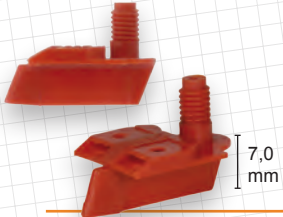

SC-1615

Guide clips for SC-1601,
SC-1602, SC-1622 and
SC-1626.

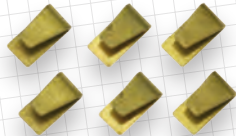

SC-1615b

Guide clips for narrow
guide (SC-1624).

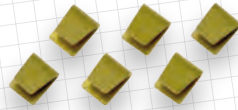

SC-1634

Tinned braid + fixing clips.

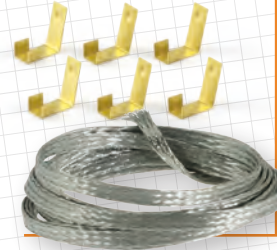

SC-1635

Tinned braid + fixing clips
for narrow guide.

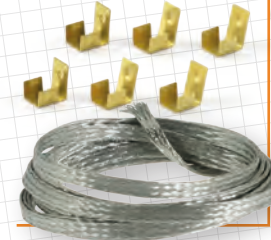

SC-1638

NEW

Narrow braid clips
(10 units)

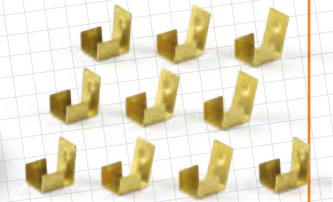

SC-1622

Heavy duty 3/16" club
racing 9,1 mm blade.

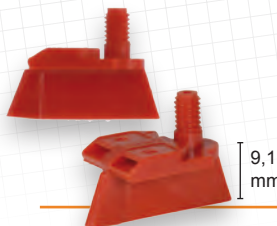

SC-1626

Racing pro guide 3/16"
club 9,1 mm blade.

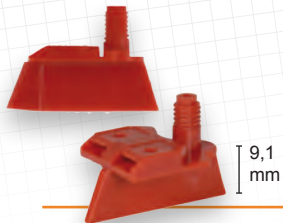

SC-1623

Steel spacers for 3/16"
guides.

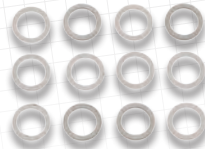

SC-1629

Nylon nut with M2
pass for 3/16 guide.

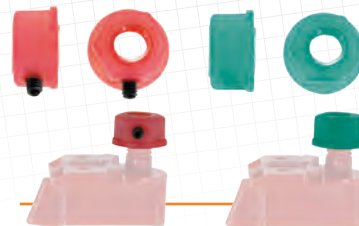

SC-1629b

Nylon nut for 3/16
guide.



SC-5116

M5 stainless
steel nuts x 2,5
mm for 3/16"
guides.

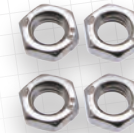

SC-1630

Tinned braid for 1/24.

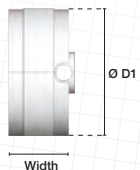

**Aluminum hubs for 3 mm axle
sponge tires**

Lightweight Design

Width	øD1	Reference
6,0 mm	21,0 mm	SC-4069
8,0 mm	21,0 mm	SC-4003
13,0 mm	21,0 mm	SC-4004

Corse Design

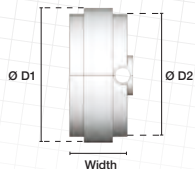
Width	øD1	Reference
10,0 mm	21,0 mm	SC-4000
16,0 mm	21,0 mm	SC-4001

**1/24 hub family
cross chart
references**

Hub Family code	D1 Diameter	Width	Solid (a)	Corse	Dakar	Jarama (e)	Lightweight (f)
4000	21,0 mm	10,0 mm		✓			
4001	21,0 mm	16,0 mm		✓			
4019	22,2 mm	9,0 mm					✓
4029	20,5 mm	10,2 mm					✓
4036	22,2 mm	11,5 mm					✓
4037	22,2 mm	9,0 mm					✓
4042	23,2 mm	10,0 mm	✓				
4043	23,2 mm	13,0 mm	✓				
4050	22,0 mm	13,0 mm					✓
4055	22,0 mm	10,0 mm					✓
4056	21,0 mm	13,0 mm				✓	✓
4057	21,0 mm	10,0 mm				✓	✓
4073	20,7 mm	11,0 mm			✓		
4074	21,3 mm	11,0 mm			✓		

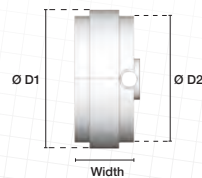
**Aluminum hubs for 3 mm axle
rubber tires**

Dakar Design

Width	øD1	øD2	Reference
11,0 mm	20,7 mm	18,5 mm	SC-4073
11,0 mm	21,3 mm	19,1 mm	SC-4074

Solid Design

Width	øD1	øD2	Reference
10,0 mm	23,5 mm	21,5 mm	SC-4042
13,0 mm	23,5 mm	21,5 mm	SC-4043

Lightweight Design

Width	øD1	øD2	Reference
9,0 mm	22,2 mm	20,0 mm	SC-4037b
10,0 mm	21,0 mm	19,0 mm	SC-4057f
10,0 mm	22,0 mm	20,0 mm	SC-4055f
10,2 mm	19,5 mm	17,3 mm	SC-4019
10,2 mm	20,5 mm	18,0 mm	SC-4029
11,5 mm	22,2 mm	20,0 mm	SC-4036b
13,0 mm	21,0 mm	19,0 mm	SC-4056f
13,0 mm	22,0 mm	20,0 mm	SC-4050f

Jarama

Width	øD1	øD2	Reference
10,0 mm	21,0 mm	19,0 mm	SC-4057e
13,0 mm	23,0 mm	19,0 mm	SC-4056e

Rubber tyre measures

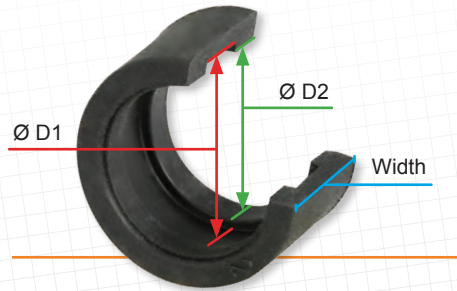

Scaleauto offers a wide range of rubber tires for 1/24 scale, including various sizes and compounds for different kinds of track to fulfill the needs of most racers and model makers.

Size and brand name is engraved on the side of all tires for a quick simple identification.

Surface type:

- Slick:** For race track purposes
- Stripped:** For modern road cars replicas
- Dirt Rally:** Special cutted tyre for rally powder conditions.

Hardness compounds:

- Standard:** Used in the original cars starting from 2014 year • Ninco - Scalextric - SCX
- Zero Grip:** Minimum friction surface for front wheels only.
- RT:** Harder with higher grip
Ninco - Scalextric - SCX
- Medium:** Intermediate GriP
Carrera - Wood - Ninco
- Soft:** High grip for smooth surfaces
Scalextric Sport - Carrera
(glued to hubs only).

Rubber tires

Width	øD1	Minimum øD2	Slick				Stripped		Dirt Rally
			Standard	RT	Medium	Soft	RT	Soft	Soft
10,0 mm	26,0 mm	20,0 mm	SC-4716						
12,0 mm	24,0 mm	16,0 mm		SC-4732		SC-4731	SC-4730	SC-4729	SC-4729ba
13,0 mm	25,0 mm	20,0 mm						SC-4725	
13,0 mm	25,0 mm	19,0 mm		SC-4749	SC-4737				
13,0 mm	27,0 mm	20,0 mm	SC-4717						

1/24 rubber tires compatibility cross chart

Hub Family code	D1 Diameter	Width	Standard	RT	Medium	Soft	RT Stripped	Soft Stripped
4019	22,2 mm	9,0 mm	SC-4716					
4029	20,5 mm	10,2 mm		SC-4732		SC-4731	SC-4730	SC-4729 / SC-4729ba
4036	22,2 mm	11,5 mm		SC-4732		SC-4731	SC-4730	SC-4729 / SC-4729ba
4037	22,2 mm	9,0 mm	SC-4716					
4042	23,2 mm	10,0 mm	SC-4716	SC-4732		SC-4731	SC-4730	SC-4729 / SC-4729ba
4043	23,2 mm	13,0 mm	SC-4717	SC-4749	SC-4737			SC-4725
4050	22,0 mm	13,0 mm	SC-4717	SC-4749	SC-4737			SC-4725
4055	22,0 mm	10,0 mm	SC-4716	SC-4732	SC-4731		SC-4730	SC-4729 / SC-4729ba
4056	21,0 mm	13,0 mm		SC-4749	SC-4737			SC-4725
4057	21,0 mm	10,0 mm		SC-4732				

Sponge tyre measures

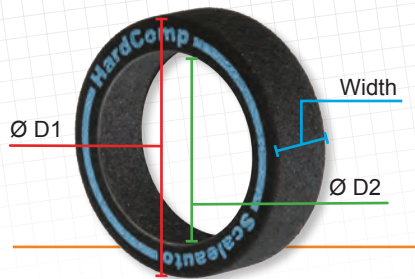

Width	D1	D2	Procomp	Procomp 2	Procomp 3	Procomp 4	Hardcomp
9,0 mm	26,5 mm	21,0 mm					
10,0 mm	27,0 mm	16,0 mm	SC-4814				
12,0 mm	28,0 mm	20,0 mm		SC-4854			SC-4840
13,0 mm	24,0 mm	10,0 mm	SC-4811				
14,0 mm	26,5 mm	21,0 mm		SC-4851			
14,0 mm	26,5 mm	21,6 mm					
15,0 mm	29,0 mm	16,0 mm	SC-4815				
16,0 mm	27,0 mm	21,0 mm	SC-4818				
16,0 mm	29,0 mm	19,0 mm	SC-4819				
20,0 mm	30,0 mm	16,0 mm					SC-4822
20,0 mm	30,5 mm	20,0 mm					SC-4820
20,0 mm	30,0 mm	16,0 mm	SC-4804	SC-4852	SC-4832		
20,0 mm	30,0 mm	20,0 mm	SC-4802	SC-4850	SC-4830		
35,0 mm	30,0 mm	15,0 mm	SC-4803				
35,0 mm	19,0 mm	12,0 mm	SC-4805				

Wheel inserts

SC-7606

Speedline 6 spokes wheel insert ø 20 mm.

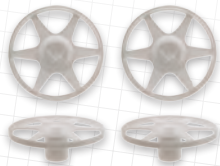

SC-7610

BBS GT wheel insert ø 20 mm with brake disk.

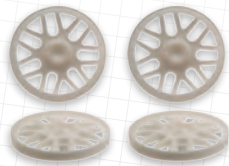

SC-7618

15 spokes modern GT LMS hubs ø 20 mm with brake disk.

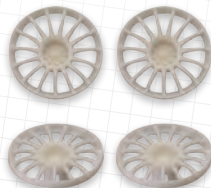

SC-7607

OZ wheel insert ø 16/17 mm.

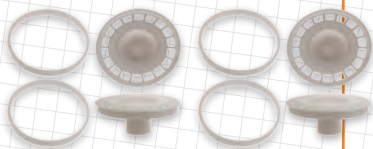

SC-7608

Speedline 15 spokes wheel insert ø 20 mm.

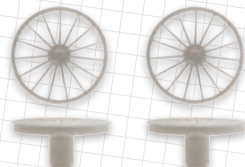

SC-7615

BBS GT 15 spokes wheel insert ø 20 mm with brake disk.

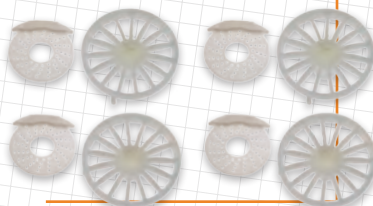

SC-7619

5 spokes classic wheel insert ø 17-19 mm.

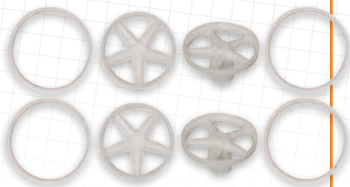

SC-7621

BMW M Sport wheel insert ø 20 mm.

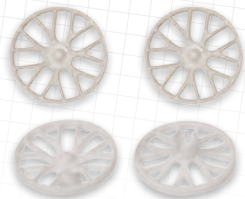

SC-7622

7 spoke SRT Sport wheel insert ø 20 mm.

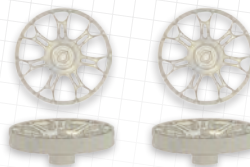

Self sticking ballast

SC-1510

100 x 50 x 1,5 mm

SC-1511

100 x 50 x 1 mm

SC-1512

100 x 50 x 0,5 mm

SC-1512

100 x 50 x 2 mm

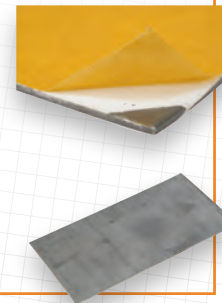

SC-3500

Carbon fiber sheet
140 x 62 x 1 mm

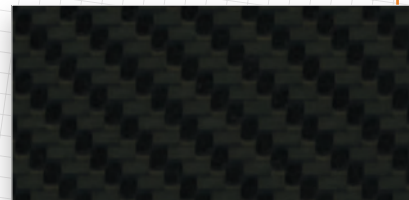

SC-MK001

Scaleauto textile banners for track cover.
0,8 m heig. Sold in 50 m rolls.



SC-MK002

Scaleauto textile lanyards.

NEW



SC-MK003

Race car precutted lane stickers.

NEW



Chassis ground clearance tools

Reference	Description
SC-5003	Tech tool for chassis ground clearance 1 mm
SC-5004	Tech tool for chassis ground clearance 1,3 mm
SC-5005	Tech tool for chassis ground clearance 2 mm
SC-5006	Tech tool for chassis ground clearance 1 / 1,2 mm
SC-5007	Tech tool for chassis ground clearance 1,3 / 1,5 mm



Acrylic car shelves

SC-5056

1/32 acrylic car shelf for 2 cars.

SC-5057

1/24 acrylic car shelf for 2 cars.



Specially designed for professional races

- Convenient transportation platforms for race organization and as storage solution.
- Keeps your car tires away from dirt and avoids direct hand manipulation.
- Expandable from two to eight lanes.
- Available in two sizes: for 1/32 and 1/24 scale cars.

SC-5058

1/32 acrylic car shelf for 4 cars.

SC-5061

1/24 acrylic car shelf for 4 cars.



SC-5059

1/32 acrylic car shelf for 6 cars.

SC-5062

1/24 acrylic car shelf for 6 cars.



SC-5060

1/32 acrylic car shelf for 8 cars.

SC-5063

1/24 acrylic car shelf for 8 cars.



Porsche 991 RSR

NEW

 24h LM 2013 #91
 Porsche AG Team Manthey

SC-6066

R HS

NEW

 24h LM 2013 #92 Winner
 Porsche AG Team Manthey

SC-6065

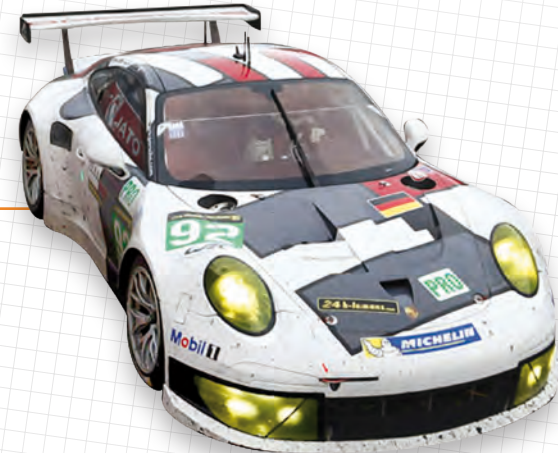
R HS

	Reference	Motor	Motor Size	Magnet	Chassis	Lightweight interior	Gear	Pinion	Front		Rear	
									ø Tire	Hub	ø Tire	Hub
24h LM 2013 #91	SC-6065	SC-08b	Sidewinder		HS	X	32 tooth	12 tooth	18 x 9 Standard	17,5 x 9 Plastic	19 x 10,5 Standard	17,5 x 10 Plastic
24h LM 2013 #92 Winner	SC-6066		Short Can									
24h LM 2013 #91	SC-6065R	Anglewinder	✓	R	✓	27 tooth	18 x 9 Standard		17,5 x 9 Plastic	19 x 10,5 Standard	17,5 x 10 Aluminum	
24h LM 2013 #92 Winner	SC-6066R	Long Can										

SRT Viper GTS-R

NEW

24h LM 2013 #93
SRT Motorsport Team Viper

SC-6036

R HS
**NEW**

Official Racing Team

SC-6038

R HS
**NEW**

24h LM 2013 #53
SRT Motorsport Team Viper

SC-6037

R HS

	Reference	Motor	Motor Size	Magnet	Chassis	Lightweight interior	Gear	Pinion
24h LM 2013 #93	SC-6036		Sidewinder					
24h LM 2013 #53	SC-6037	SC-08b	Short Can		HS	X	32 tooth	
Official Racing Team #91	SC-6038			✓				12 tooth
24h LM 2013 #93	SC-6036R		Anglewinder					
24h LM 2013 #53	SC-6037R	SC-25b			R	✓	27 tooth	
Official Racing Team #91	SC-6038R		Long Can					

	Reference	Front		Rear	
		ø Tire	Hub	ø Tire	Hub
24h LM 2013 #93	SC-6036				
24h LM 2013 #53	SC-6037	18 x 9 Standard	17,5 x 9 Plastic	19 x 10,5 Standard	17,5 x 10 Plastic
Official Racing Team #91	SC-6038				
24h LM 2013 #93	SC-6036R				
24h LM 2013 #53	SC-6037R	18 x 9 Standard	17,5 x 9 Plastic	19 x 10,5 Standard	17,5 x 10 Aluminum
Official Racing Team #91	SC-6038R				

HSV-010 Super GT

NEW

JGTC 2010 #18
Weider

SC-6033

R HS



JGTC 2010 Presentation
Raybrig

SC-6012

R3

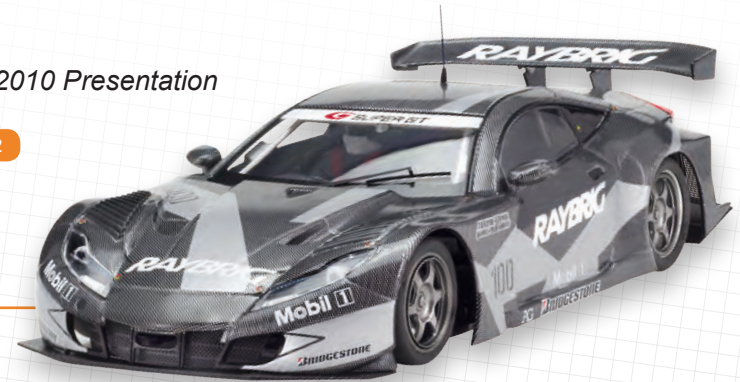

JGTC 2010 #100
Raybrig

SC-6031

R3

Rev2



JGTC 2010 #8
Autobacs

SC-6015

R3

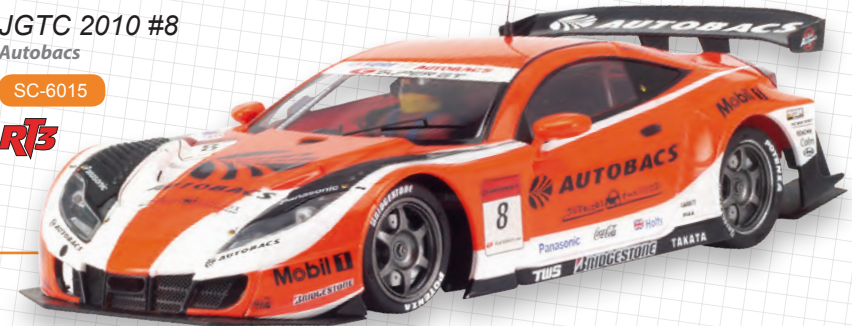

	Reference	Motor	Motor Size	Magnet	Chassis	Gear	Pinions	Lightweight interior	Front		Rear	
									ø Tire	Hub	ø Tire	Hub
JGTC 2010 Presentation	SC-6012	SC-08b	Sidewinder Short Can	✓	R3 Rev1	32 tooth	12 tooth	✗	18 x 9 Standard	17,5 x 9 Plastic	19 x 10,5 Standard	17,5 x 10 Aluminum
JGTC 2010 #8	SC-6015				R3 Rev2				18 x 9 Standard	17,5 x 9 Plastic	19 x 10,5 Standard	17,5 x 10 Plastic
JGTC 2010 #100	SC-6031				R3 Rev2				18 x 9 Standard	17,5 x 9 Plastic	19 x 10,5 Standard	17,5 x 10 Plastic
JGTC 2010 #18	SC-6033	SC-25b	Anglewinder Long Can	✓	HS	27 tooth	✓	18 x 9 Standard	17,5 x 9 Plastic	19 x 10,5 Standard	17,5 x 10 Aluminum	
JGTC 2010 #18	SC-6033R				R			18 x 9 Standard	17,5 x 9 Plastic	19 x 10,5 Standard	17,5 x 10 Aluminum	

SLS AMG GT3

Laureus Special Edition

SC-6019



Limited
500 pcs.

VLN Nürburgring 2011 #15
Mamerow Racing

SC-6021



NEW

IberGT 2011 Jarama #25
Vodafone BP Ultimate Team

SC-6022



	Reference	Motor	Motor Size	Magnet	Chassis	Lightweight interior	Gear	Pinions
Laureus Special Edition	SC-6019		In-line					9 tooth
VLN Nürburgring 2011 #5	SC-6021	SC-26	Long Can Anglewinder	✓	RT2	✗	27 tooth	
IberGT 2011 Jarama #25	SC-6022	SC-25b	Long Can					12 tooth

	Reference	Front		Rear	
		ø Tire	Hub	ø Tire	Hub
Laureus Special Edition	SC-6019				
VLN Nürburgring 2011 #5	SC-6021	18 x 9 Standard	17,5 x 9 Plastic	19 x 10,5 Standard	17,5 x 10 Aluminum
IberGT 2011 Jarama #25	SC-6022				

BMW Z4 GT3

24h Barcelona 2011 #2
Schubert Motorsport

SC-6020

R13
Rev2



Super GT 2011 #4
Studie AGs

SC-6028

R13
Rev2



NEW

24h Nürburgring 2013 #19
Schubert Motorsport

SC-6032

R HS



	Reference	Motor	Motor Size	Magnet	Chassis	Lightweight interior	Gear	Pinions	Front		Rear	
									ø Tire	Hub	ø Tire	Hub
24h Barcelona 2011 #2	SC-6020	SC-08b	Sidewinder	✓	R13 Rev2	X	32 tooth	12 tooth	18 x 9 Standard	17,5 x 9 Plastic	19 x 10,5 Standard	17,5 x 10 Aluminum
Super GT 2011 #4	SC-6028		Short Can		HS				18 x 9 Standard	17,5 x 9 Plastic	19 x 10,5 Standard	17,5 x 10 Plastic
24h Nürburgring 2013 #19	SC-6032	SC-25b	Anglewinder	✓	R	✓	27 tooth	12 tooth	18 x 9 Standard	17,5 x 9 Plastic	19 x 10,5 Standard	17,5 x 10 Aluminum
24h Nürburgring 2013 #19	SC-6032R	Long Can			R				18 x 9 Standard	17,5 x 9 Plastic	19 x 10,5 Standard	17,5 x 10 Aluminum

NEW

VLN Nürburgring 2012 #20
Schubert Motorsport

SC-6069

R HS**NEW**

24h Nürburgring 2013 #20
Schubert Motorsport

SC-6070

R HS**NEW**

Silverstone 2011 #40 Winner
Marc VDS Racing Team

SC-6074

R HS

	Reference	Motor	Motor Size	Magnet	Chassis	Lightweight interior	Gear	Pinions	Front		Rear	
									ø Tire	Hub	ø Tire	Hub
VLN Nürburgring 2012 #20	SC-6069	SC-08b	Sidewinder	✓	HS	X	32 tooth	12 tooth	18 x 9 Standard	17,5 x 9 Plastic	19 x 10,5 Standard	17,5 x 10 Plastic
24h Nürburgring 2013 #20	SC-6070		Short Can									
Silverstone 2011 #40 Winner	SC-6074	SC-25b	Anglewinder	✓	R	✓	27 tooth	12 tooth	18 x 9 Standard	17,5 x 9 Plastic	19 x 10,5 Standard	17,5 x 10 Aluminum
VLN Nürburgring 2012 #20	SC-6069R		Long Can									
24h Nürburgring 2013 #20	SC-6070R											
Silverstone 2011 #40 Winner	SC-6074R											

C8 Spyder

NEW

C8 Spyder GT2R 24h LM
2006 #85
Spyker Squadron BV

SC-6053

R HS
NEW

C8 Spyder GT2R 24h LM
2006 #86
Spyker Squadron BV

SC-6042

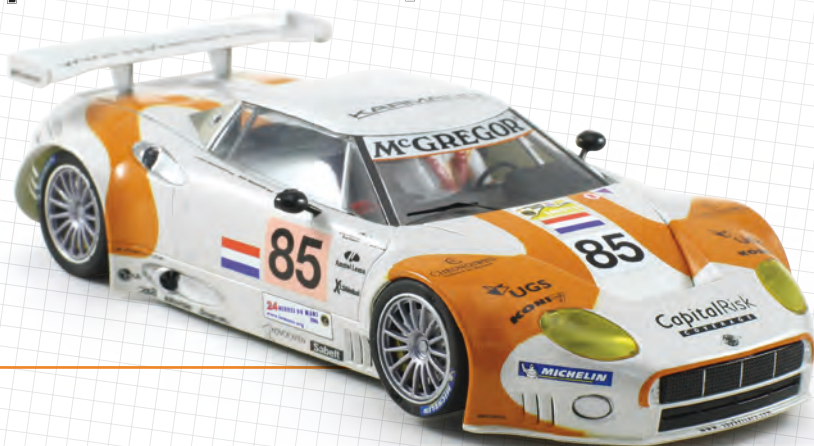
R HS

C8 Laviolette

NEW

C8 Laviolette GT2R 24h
LM 2008 #85
Spyker Squadron BV

SC-6050

R HS
NEW

C8 Laviolette GT2R 24h
LM 2008 #94
Spyker Squadron BV

SC-6051

R HS

	Reference	Motor	Motor Size	Magnet	Chassis	Lightweight interior	Gear	Pinion
C8 Spyder GT2R 24h LM 2006 #86	SC-6042	SC-08b	Sidewinder 	✓	HS	✗	32 tooth	12 tooth
C8 Laviolette GT2R LM 2008 #85	SC-6050							
C8 Laviolette GT2R LM 2008 #94	SC-6051							
C8 Spyder GT2R 24h LM 2006 #85	SC-6053	SC-25b	Anglewinder 	✓	R	✓	27 tooth	
C8 Spyder GT2R 24h LM 2006 #86	SC-6042R							
C8 Laviolette GT2R LM 2008 #85	SC-6050R							
C8 Laviolette GT2R LM 2008 #94	SC-6051R							
C8 Spyder GT2R 24h LM 2006 #85	SC-6053R		Long Can 					

Chassis	Front		Rear	
	ø Tire	Hub	ø Tire	Hub
HS	18 x 9 Standard	17,5 x 9 Plastic	19 x 10,5 Standard	17,5 x 10 Plastic
R	18 x 9 Standard	17,5 x 9 Plastic	19 x 10,5 Standard	17,5 x 10 Aluminum

Pagani Zonda

24h LM Test 2004 #60
Force One Racing

SC-6045



NEW

12h Sebring 2003 #17

SC-6071



	Reference	Motor	Motor Size	Magnet	Chassis	Front		Rear	
						ø Tire	Hub	ø Tire	Hub
24h LM Test 2004 #60	SC-6045	SC-26	In-line Long Can	✓	RT2	18 x 9 Standard	17,5 x 9 Plastic	19 x 10,5 Standard	17,5 x 10 Aluminum
12h Sebring 2003	SC-6071	SC-25b	Anglewinder Long Can						

Radical SR-9

NEW

24h LM 2010 #26
Race Performance AG

SC-6010



NEW

Racing series

SC-6096R4



SC-6096R3

SC-6096R2

SC-6096R1

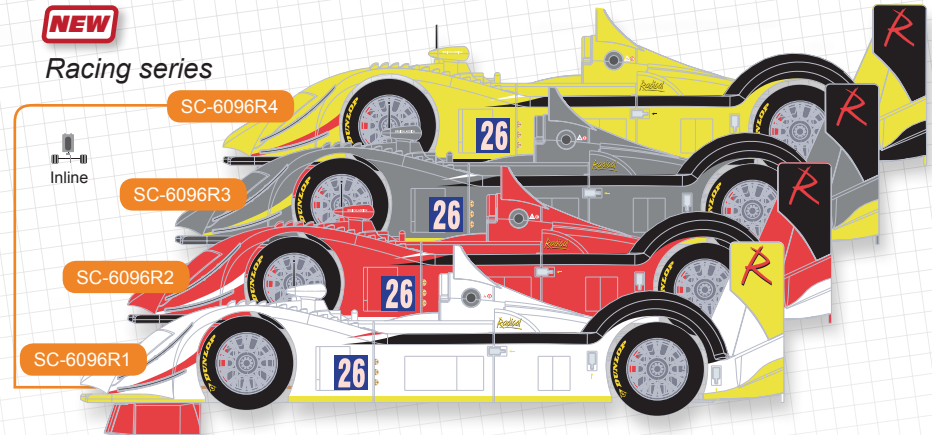

	Reference	Motor	Motor Size	Magnet	Chassis	Front		Rear	
						ø Tire	Hub	ø Tire	Hub
24h LM 2010 #28	SC-6010	SC-25b	Inline Long Can	✓	RT2	18 x 9 Standard	17,5 x 9 Plastic	19 x 10,5 Standard	17,5 x 10 Aluminum
Racing Series	SC-6069								

RS200

Rally Portugal 1986 #15
Joaquim Santos

MSC-6018



MG Metro 6R4

Camel Off-Road 1991 #4
Fernando Capdevila

MSC-6020



RAC Rally 1986 #19
Marc Duez

MSC-6025



	Reference	Motor	Motor Size	Magnet	Chassis	Gear	Pinion	Front		Rear	
								ø Tire	Hub	ø Tire	Hub
Rally Portugal 1986 #15	MSC-6018	SC-26	Inline Long Can	✓		9 tooth	27 tooth	18 x 9 Standard	17,5 x 9 Plastic	19 x 10,5 Standard	17,5 x 10 Aluminum

	Reference	Motor	Motor Size	Magnet	Chassis	Gear	Pinion	Front		Rear	
								ø Tire	Hub	ø Tire	Hub
Camel Off-Road 1991 #4	MSC-6020	SC-26	Inline	✓		9 tooth	27 tooth	18 x 9 Standard	17,5 x 9 Plastic	19 x 10,5 Standard	17,5 x 10 Aluminum
RAC Rally 1986 #19	MSC-6025		Long Can								

Subaru Impreza WRC

Rally Lana 2001 #5
Andrea Aghini

MSC-6030

RT2
Inline
4WD



Rally Kenia 2000 #3
Winner
Richard Burns

MSC-6042

RT2
Inline
4WD



NEW

Rally San Remo 1998 #20
Andrea Dallavilla

SC-6082

R HS
4WD



	Reference	Motor	Motor Size	Magnet	Chassis	Gear	Pinion	Lightweight interior	Front		Rear	
									ø Tire	Hub	ø Tire	Hub
Rally Safari 2000 #3 Winner	MSC-6042	SC-26	Inline		RT2 4WD	9 tooth	27 tooth	X	18 x 9 Standard	17,5 x 9 Plastic	19 x 10,5 Standard	17,5 x 10 Aluminum
Rally Lana 2001 #5	MSC-6030		Short Can						18 x 9 Standard	17,5 x 9 Plastic	19 x 10,5 Standard	17,5 x 10 Plastic
Rally San Remo 1998 #20	SC-6082	SC-08	Sidewinder	✓	HS	12 tooth			18 x 9 Standard	17,5 x 9 Plastic	19 x 10,5 Standard	17,5 x 10 Plastic
Rally San Remo 1998 #20	SC-6082R	SC-25b	Anglewinder						R 4WD	27 tooth	✓	18 x 9 Standard
			Long Can									

Peugeot 208 T16

NEW

Acropolis 2014 Winner

SC-6118

R HS
4WD



	Reference	Motor	Motor Size	Magnet	Chassis	Gear	Pinion	Lightweight interior	Front		Rear	
									ø Tire	Hub	ø Tire	Hub
Acropolis 2014 Winner	SC-6118	SC-08	Sidewinder Short Can		HS	32 tooth		X	18 x 9 Standard	17,5 x 9 Plastic	19 x 10,5 Standard	17,5 x 10 Plastic
Acropolis 2014 Winner	SC-6118R	SC-25b	Anglewinder Long Can	✓	R 4WD	27 tooth	12 tooth	✓	18 x 9 Standard	17,5 x 9 Plastic	19 x 10,5 Standard	17,5 x 10 Aluminum

Porsche Carrera RSR 3.0 / RS

NEW

RS Gulf #709

SC-6123

R HS



NEW

RSR 3.0 Kremer
Jagermeister #54

SC-6122

R HS



NEW

RSR 3.0
Geog Loos Team #1

SC-6121

R HS



	Reference	Motor	Motor Size	Magnet	Chassis	Lightweight interior	Gear	Pinion	Front		Rear	
									ø Tire	Hub	ø Tire	Hub
RSR 3.0 Geog Loos Team #1	SC-6121	SC-08	Sidewinder	✓	HS	✗	32 tooth	12 tooth	18 x 9 Standard	17,5 x 9 Plastic	19 x 10,5 Standard	17,5 x 10 Plastic
RSR 3.0 Kremer Jagermeister #54	SC-6122		Short Can									
RS Gulf #709	SC-6123	SC-25b	Anglewinder	✓	R	✓	27 tooth	12 tooth	18 x 9 Standard	17,5 x 9 Plastic	19 x 10,5 Standard	17,5 x 10 Aluminum
RSR 3.0 Geog Loos Team #1	SC-6121R											
RSR 3.0 Kremer Jagermeister #54	SC-6122R											
RS Gulf #709	SC-6123R		Long Can									

Porsche 959

Porsche 959

Martini

MSC-6041

Street car red

MSC-6019

Street car white

MSC-6032

Street car black

MSC-6023



	Reference	Motor	Motor Size	Magnet	Chassis	Lightweight interior	Gear	Pinion	Front		Rear	
									ø Tire	Hub	ø Tire	Hub
Porsche 959 Martini	SC-6041	SC-26	Inline				27 tooth	9 tooth	18 x 9	17,5 x 9	19 x 10,5	17,5 x 10
Street car red	SC-6019		✓	✗		Standard			Plastic	Standard	Aluminum	
Street car white	SC-6032											
Street car black	SC-6023		Long Can									

Porsche 935-76 Gr.5

DRM Zolder 1977 #52
Team Max Moritz

SC-6029

RT3
Rev2



NEW

24h Daytona 1979 Winner
Interscope Racing

SC-6047

R HS



NEW

1000 km Nürburgring
1977 #7
Liqui Moly Team

SC-6104

R HS



	Reference	Motor	Motor Size	Magnet	Chassis	Lightweight interior	Gear	Pinion	Front		Rear	
									ø Tire	Hub	ø Tire	Hub
DRM Zolder 1977 #52	SC-6029	SC-08b	Sidewinder	✓	RT3 Rev2	X	32 tooth	12 tooth	18 x 9 Standard	17,5 x 9 Plastic	19 x 10,5 Standard	17,5 x 10 Aluminum
24h Daytona 1979 Winner	SC-6047		Short Can		HS				18 x 9 Standard	17,5 x 9 Plastic	19 x 10,5 Standard	17,5 x 10 Plastic
1000 km Nürburgring 1977 #7	SC-6104	SC-25b	Anglewinder	✓	R	✓	27 tooth		18 x 9 Standard	17,5 x 9 Plastic	19 x 10,5 Standard	17,5 x 10 Aluminum
24h Daytona 1979 Winner	SC-6047R		Long Can							18 x 9 Standard	17,5 x 9 Plastic	19 x 10,5 Standard
1000 km Nürburgring 1977 #7	SC-6104R											

Porsche 935-77 Gr.5

24h Daytona 1980 #30
Electrodyn

SC-9101

HS



NEW

Silverstone 1977 #1
Martini

SC-9104

HS



New update body and chassis compatible with RT3

NEW

LeMans 1977 #41
Martini

SC-9105

HS



Limited 500 pcs.

New update body and chassis compatible with RT3

	Reference	Motor	Motor Size	Magnet	Chassis	Lightweight interior	Gear	Pinion	Front		Rear	
									ø Tire	Hub	ø Tire	Hub
24h Daytona 1980 #30	SC-9101		Sidewinder	✓	HS				18 x 9 Standard	17,5 x 9 Plastic	19 x 10,5 Standard	17,5 x 10 Plastic
Silverstone 1977 #1	SC-9104	SC-08b	Short Can	✓	HS	X	36 tooth	11 tooth	18 x 9 Standard	17,5 x 9 Plastic	19 x 10,5 Standard	17,5 x 10 Plastic
LeMans 1977 #41	SC-9105											

Porsche 935-J Gr.5

DRM Norisring 1980 #6
Liqui Moly

SC-9102



NEW

LeMans 1982 #65
Vegla

SC-9103



New update body and chassis compatible with RT3

NEW

IMSA 24h Daytona
1981 #46
DeNarvaez

SC-9106



New update body and chassis compatible with RT3

	Reference	Motor	Motor Size	Magnet	Chassis	Lightweight interior	Gear	Pinion	Front		Rear	
									ø Tire	Hub	ø Tire	Hub
DRM Norisring 1980 #6	SC-9102		Sidewinder	✓	HS				18 x 9 Standard	17,5 x 9 Plastic	19 x 10,5 Standard	17,5 x 10 Plastic
LeMans 1982 #65	SC-9103	SC-08b	Short Can	✓	HS	✗	36 tooth	11 tooth	18 x 9 Standard	17,5 x 9 Plastic	19 x 10,5 Standard	17,5 x 10 Plastic
24h Daytona 1981 #46	SC-9106											

M1 Gr.5

Le Mans 1981 #50
Team GS Sport BASF

SC-6049

R13

Rev2



NEW

Le Mans 1981 #51
VSD

SC-6059

R HS



	Reference	Motor	Motor Size	Magnet	Chassis	Lightweight interior	Gear	Pinion	Front		Rear	
									ø Tire	Hub	ø Tire	Hub
Le Mans 1981 #50	SC-6049	SC-08	Sidewinder	✓	R13 Rev2	✗	32 tooth	12 tooth	18 x 9 Standard	17,5 x 9 Plastic	19 x 10,5 Standard	17,5 x 10 Aluminum
Le Mans 1981 #51	SC-6059		Short Can		HS				18 x 9 Standard	17,5 x 9 Plastic	19 x 10,5 Standard	17,5 x 10 Plastic
Le Mans 1981 #51	SC-6059R	SC-25b	Anglewinder	✓	R	✓	27 tooth	12 tooth	18 x 9 Standard	17,5 x 9 Plastic	19 x 10,5 Standard	17,5 x 10 Aluminum
			Long Can									

Fuji 1982 #8
Seelex Racing Team

SC-6039



Rev2



Le Mans 1981 #53
BMW Australia

SC-6024



Rev2

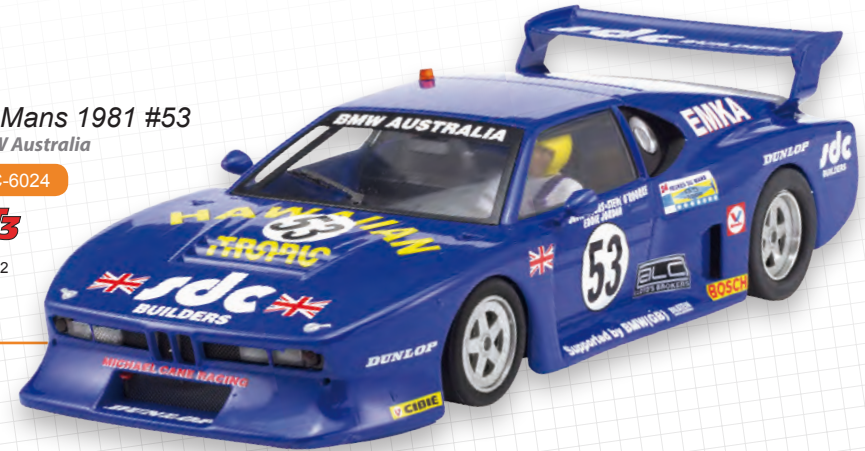

NEW

Le Mans 1981 #52
Sauber BMW Austria

SC-6027

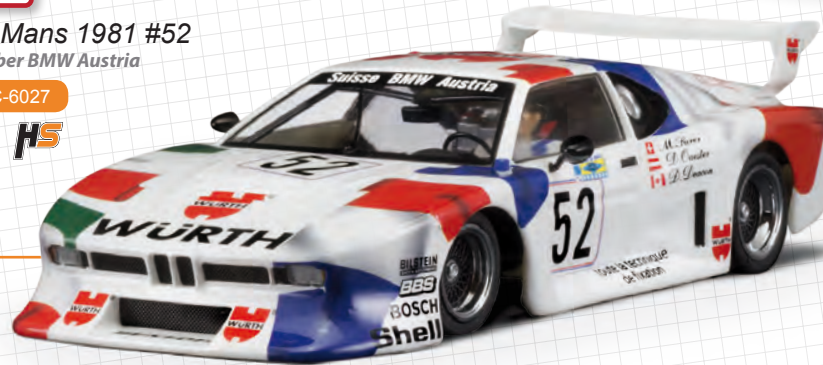

	Reference	Motor	Motor Size	Magnet	Chassis	Lightweight interior	Gear	Pinion	Front		Rear	
									ø Tire	Hub	ø Tire	Hub
Le Mans 1981 #53	SC-6024	SC-08	Sidewinder	✓	RT3 Rev2	X	32 tooth	12 tooth	18 x 9 Standard	17,5 x 9 Plastic	19 x 10,5 Standard	17,5 x 10 Aluminum
Fuji 1982 #8	SC-6039		Short Can		HS				18 x 9 Standard	17,5 x 9 Plastic	19 x 10,5 Standard	17,5 x 10 Plastic
Le Mans 1981 #52	SC-6027	Anglewinder			R	✓	27 tooth		18 x 9 Standard	17,5 x 9 Plastic	19 x 10,5 Standard	17,5 x 10 Aluminum
Le Mans 1981 #52	SC-6027R	SC-25b	Long Can									

De Tomaso Pantera Gr.3

Tour Auto 1973 #85
Bernard de Dryver

MSC-6029

R3
Rev2



NEW

24h LM 1975 #7
Beurlys Inter Auto

SC-6035

R HS



	Reference	Motor	Motor Size	Magnet	Chassis	Lightweight interior	Gears	Pinion	Front		Rear	
									ø Tire	Hub	ø Tire	Hub
Tour Auto 1973 #85	MSC-6029	SC-08b	Sidewinder	✓	R3 Rev2	✗	32 tooth	12 pinions	18 x 9 Standard	17,5 x 9 Plastic	19 x 10,5 Standard	17,5 x 10 Aluminum
24h LM 1975 #7	SC-6035		Short Can		HS				18 x 9 Standard	17,5 x 9 Plastic	19 x 10,5 Standard	17,5 x 10 Palstic
24h LM 1975 #7	SC-6035R	SC-25b	Anglewinder Long Can		R	✓	27 tooth		18 x 9 Standard	17,5 x 9 Plastic	19 x 10,5 Standard	17,5 x 10 Aluminum

NEW

Bonhorst DRM 1975 #318
Jägermeister

SC-6040

R HS



NEW

Rally Montecarlo 1976 #43
Pittoni

SC-6084

R HS



Tour Auto 1973 #83
Jean Vinatiers

MSC-6040

R3

Rev2



	Reference	Motor	Motor Size	Magnet	Chassis	Lightweight interior	Gears	Pinion	Front		Rear	
									ø Tire	Hub	ø Tire	Hub
Tour Auto 1973 #83	MSC-6040	SC-08b	Sidewinder	✓	R3 Rev2	X	32 tooth	12 pinions	18 x 9 Standard	17,5 x 9 Plastic	19 x 10,5 Standard	17,5 x 10 Aluminum
Bonhorst DRM 1975 #318	SC-6040		Short Can		HS				18 x 9 Standard	17,5 x 9 Plastic	19 x 10,5 Standard	17,5 x 10 Palstic
Rally Montecarlo 1976 #43	SC-6084	SC-25b	Anglewinder	✓	R	✓	27 tooth		18 x 9 Standard	17,5 x 9 Plastic	19 x 10,5 Standard	17,5 x 10 Aluminum
Bonhorst Bergrennen 1975 #155	SC-6040R		Long Can									
Rally Montecarlo 1976 #43	SC-6084R											

Mini All4

NEW

Rally Dakar 2012 #302 Winner
Peterhansel / Cottret

SC-6092



NEW

Rally Dakar 2012 #305
Roma / Périn

SC-6093



NEW

Rally Dakar 2012 #312
Leal Dos Santos / Flúza

SC-6111



NEW

Rally Dakar 2012 #312
Novitskiy / Schulz

SC-6112



	Reference	Motor	Motor Size	Magnet	Chassis	Lightweight interior	Front		Rear	
							ø Tire	Hub	ø Tire	Hub
Rally Dakar 2012 #302 Winner	SC-6092									
Rally Dakar 2012 #305	SC-6093									
Rally Dakar 2012 #312	SC-6111	SC-08b	Sidewinder Short Can	✓		✗	24,5 x 10 Standard	16 x 8,5 Aluminum	24,5 x 10 Aluminum	16 x 8,5 Aluminum
Rally Dakar 2012 #309	SC-6112									
White racing kit	SC-6114									

Porsche 959 Raid

NEW

Dakar 1986 #187
Kussmaul

SC-6091



NEW

Raid Challenge

SC-6090a

SC-6090b

SC-6090c



	Reference	Motor	Motor Size	Magnet	Chassis	Lightweight interior	Front		Rear	
							ø Tire	Hub	ø Tire	Hub
White racing kit	SC-6089		Sidewinder	✓		✗	22 x 10 Standard	16 x 8,5 Aluminum	22 x 10 Aluminum	16 x 8,5 Aluminum
Raid Challenge	SC-6090a/b/c	SC-08b	Short Can	✓		✗	22 x 10 Standard	16 x 8,5 Aluminum	22 x 10 Aluminum	16 x 8,5 Aluminum
Dakar 1986 #187	SC-6091		Short Can	✓		✗	22 x 10 Standard	16 x 8,5 Aluminum	22 x 10 Aluminum	16 x 8,5 Aluminum



205 T16 Grand Raid

NEW

Paris Dakar 1989
 #205 Guy Frequelin
 #207 Philippe Wambergue

SC-6106



4WD

*Resine body



Limited 200 pcs.

Paris Dakar 1987
 #206 Shekhar Mehta
 #207 Andrea Zanussi

MSC-7402



4WD

*Resine body



Limited 200 pcs.



Africa Legends

	Reference	Motor	Motor Size	Magnet	Chassis	Lightweight interior	Front		Rear	
							ø Tire	Hub	ø Tire	Hub
Paris Dakar 1989 #205 / #207	SC-6106	SC-08b	Sidewinder	X		X	22 x 10	16 x 8,5	22 x 10	16 x 8,5
Paris Dakar 1987 #206 / #207	MSC-7402		Short Can				Standard	Aluminum	Aluminum	Aluminum

405 T16 Grand Raid

Paris Dakar 1988
#204 Ari Vatanen
#206 Henry Pescarolo

MSC-7404



4WD

*Resine body



Limited 200 pcs.

NEW

Paris Dakar 1989
#204 Ari Vatanen Winner
#206 Jackie Ickx

SC-6120



4WD

*Resine body



Limited 200 pcs.

	Reference	Motor	Motor Size	Magnet	Chassis	Lightweight interior	Front		Rear	
							ø Tire	Hub	ø Tire	Hub
Paris Dakar 1989 #204 Winner / #206	SC-6120	SC-08b	Sidewinder	X		X	22 x 10 Standard	16 x 8,5 Aluminum	22 x 10 Aluminum	16 x 8,5 Aluminum
Paris Dakar 1988 #204 / #206	MSC-7404		Short Can							



Range Rover

NEW

Paris Dakar 1991 #217
Trident
Salvador Servia / J.Puig

SC-6088



4WD

*Resine body



Limited 200 pcs.

NEW

Paris Dakar 1987
#198 / #199
Camel Team

SC-6095



4WD

*Resine body



Limited 200 pcs.

NEW

Paris Dakar 1987 #208
Camel Team

SC-6109



4WD

*Resine body



Limited 200 pcs.

Africa Legends

	Reference	Motor	Motor Size	Magnet	Chassis	Lightweight interior	Front		Rear	
							ø Tire	Hub	ø Tire	Hub
Paris Dakar 1991 #217	SC-6088		Sidewinder							
Paris Dakar 1987 #198 / #199	SC-6095	SC-08b	Short Can	✓		X	24,5 x 10 Standard	16 x 8,5 Aluminum	24,5 x 10 Aluminum	16 x 8,5 Aluminum
Paris Dakar 1987 #208	SC-6109									

Porsche 911 SC

NEW

Paris Dakar 1988 #221
Foltene

SC-6086



*Resine body



Limited 200 pcs.

NEW

Paris Dakar 1984 #176
Rothmans

SC-6087



4WD

*Resine body



Limited 200 pcs.

	Reference	Motor	Motor Size	Magnet	Chassis	Lightweight interior	Front		Rear	
							ø Tire	Hub	ø Tire	Hub
Paris Dakar 1988 #221	SC-6086	SC-08b	Sidewinder	✓		✗	22 x 10 Standard	16 x 8,5 Aluminum	22 x 10 Aluminum	16 x 8,5 Aluminum
Paris Dakar 1984 #176	SC-6087		Short Can	✓			22 x 10 Standard	16 x 8,5 Aluminum	22 x 10 Aluminum	16 x 8,5 Aluminum



RT3

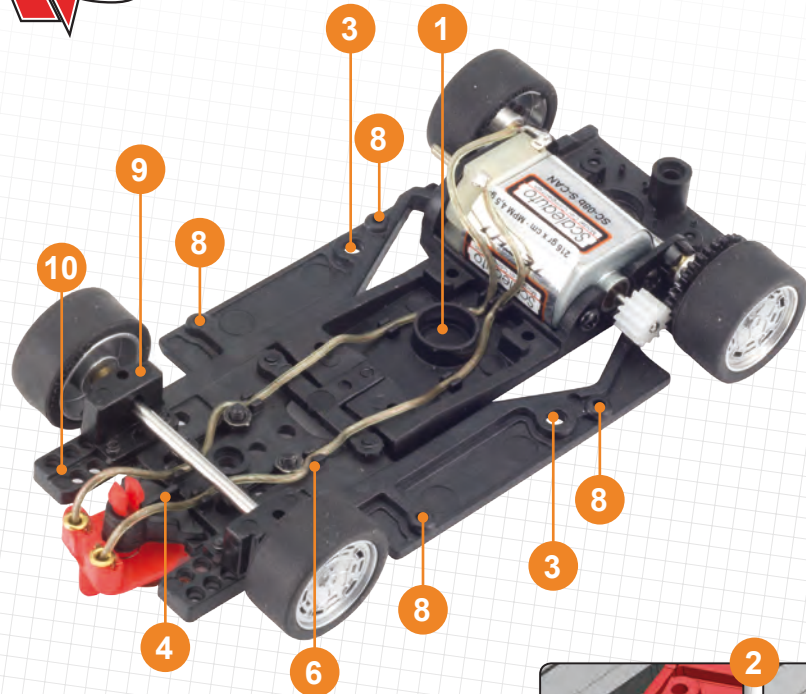

Technical Specifications

1. Independent motor mount allows for SW-AW-IL motor setup compatible with third party brands.
2. Motor mount with 2 front fixing arms style geometry design.
3. Adjustable side motor mount suspension post.
4. Guide holder adjusts the guide distance independently from front and rear axle.
5. Guide holder available in two different lengths.
6. Integrated wire fixing clips.
7. Easily adjustable rear magnet assembly.
8. Body floating concept allows adjustment of body ground clearance and balance regulation. Uses SC-5128 special screws.
9. Front axle height adjustment.
10. Adjustable wheelbase.
11. Symmetrical and asymmetrical front axle holders.

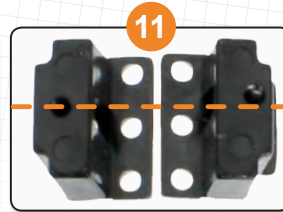
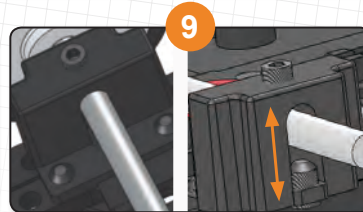
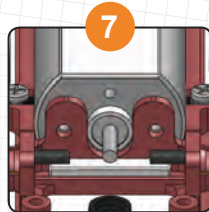
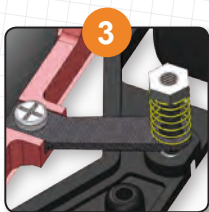
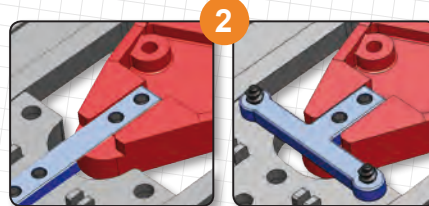

Rev3 Improvements:

1. New guide holder reinforced.
2. New chassis more rigid and stable.
3. New readjusted front axle holders for perfect fit.
4. Engravings to identify each chassis.

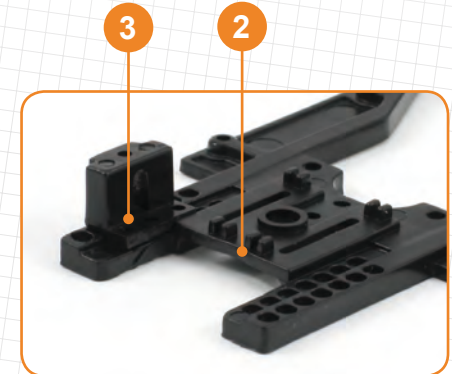

Body floating system:

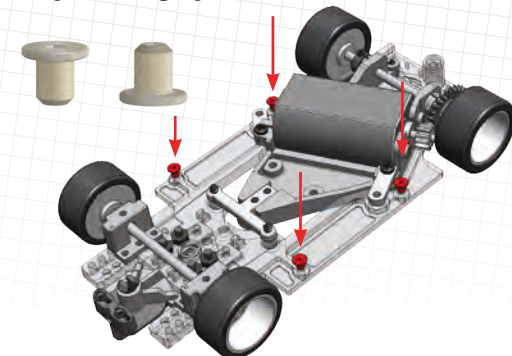

SC-6623

Chassis RT3 MWB assembled + LWB main base as optional assembly. **Rev3**

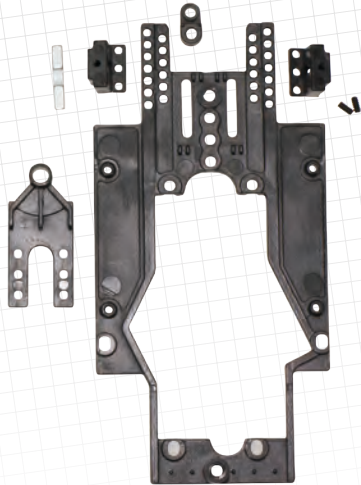
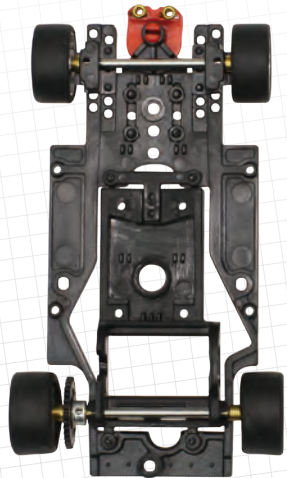

LWB

SC-6629

Long wheel base chassis (hard). **Rev3**

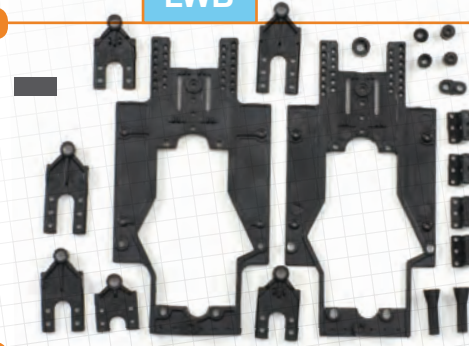

SC-6629b

Long wheel base chassis (soft). **Rev3**



Width: 57,0 mm
Wheelbase: 81-86 mm

MWB

SC-6615

Medium wheel base chassis (hard). **Rev3**

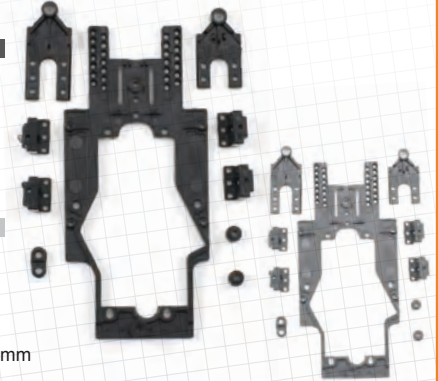

SC-6615b

Medium wheel base chassis (soft). **Rev3**

Width: 50,6 mm
Wheelbase: 77-84 mm

SWB

NEW

SC-6622

Small wheel base chassis (hard). **Rev3**

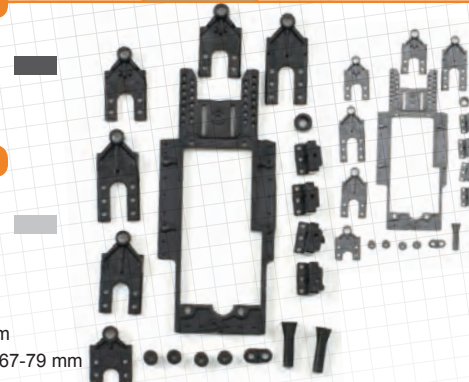

SC-6622b

Small wheel base chassis (soft). **Rev3**

Width: 44 mm
Wheelbase: 67-79 mm

XSWB

NEW

SC-6628

X-Small wheel base chassis (hard). **Rev3**

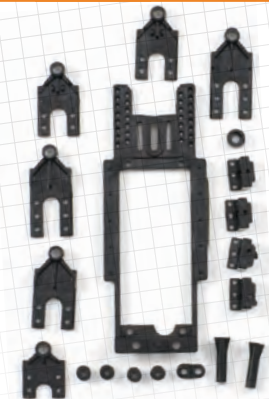

Width: 40 mm
Wheelbase: 67-73 mm



Montecarlo Chassis 4WD

The versatile Montecarlo chassis is in the core of Rally classic cars.

A large community of satisfied users is the best proof of its reliability and excellence in design and manufacturing. A wide range of spares and accessories makes the Montecarlo chassis the right choice for the rally slot driver with high expectations.

Chassis Montecarlo.

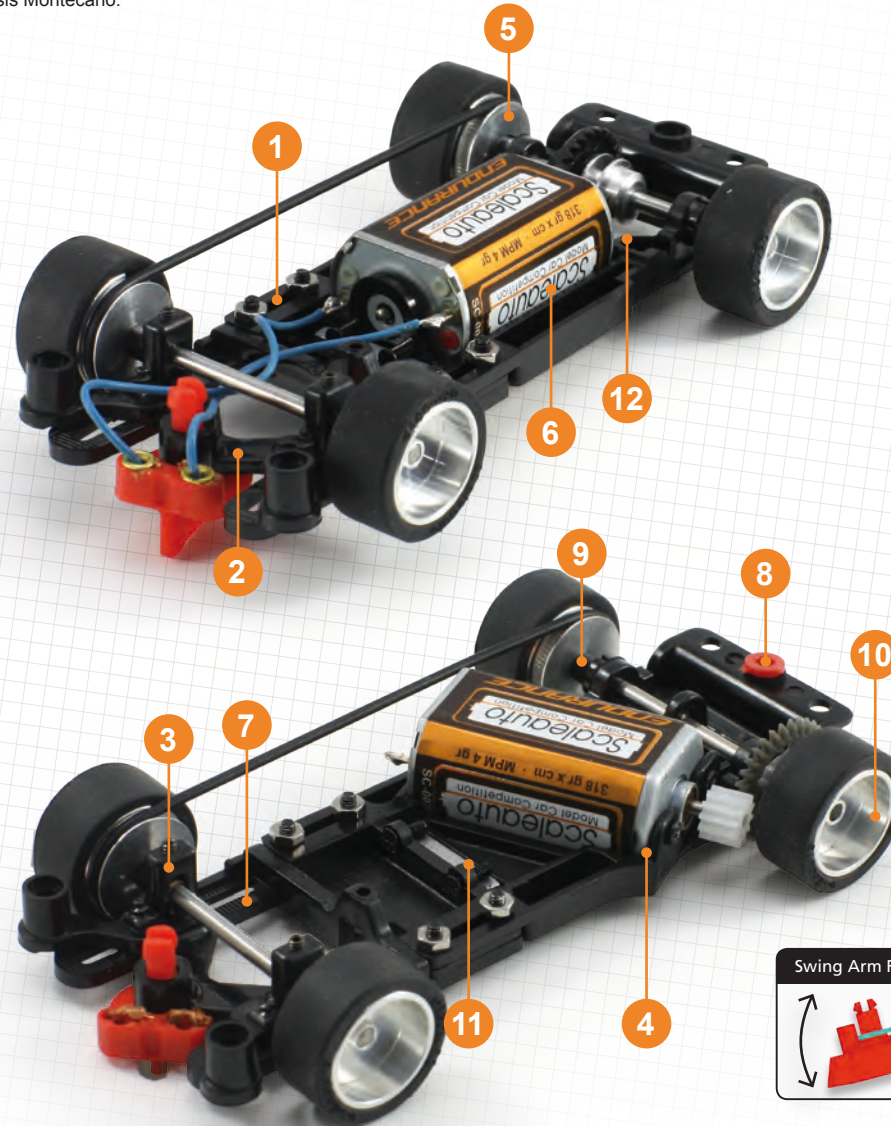

Technical Specifications

1. Adjustable wheelbase.
2. Pick up support with different distance possibilities between pick up and rear axle.
3. Suspension in front axle.
4. Two different motor mounts: in-line and anglewinder.
5. Direct transmission to rear axle and 4WD by pulleys.
6. Motor SC-26.
7. Swing arm function optionally with three different lengths and adjustable tilt angle.
8. Rubber silent-blocks for noise reduction.
9. Rear axle self centered bushing.
10. Aluminum rims.
11. Front magnet position.
12. Rear magnet position.

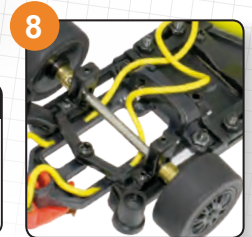
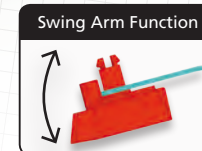

SC-6900

Chassis Montecarlo complete set.



SC-6901

Basic starter kit.

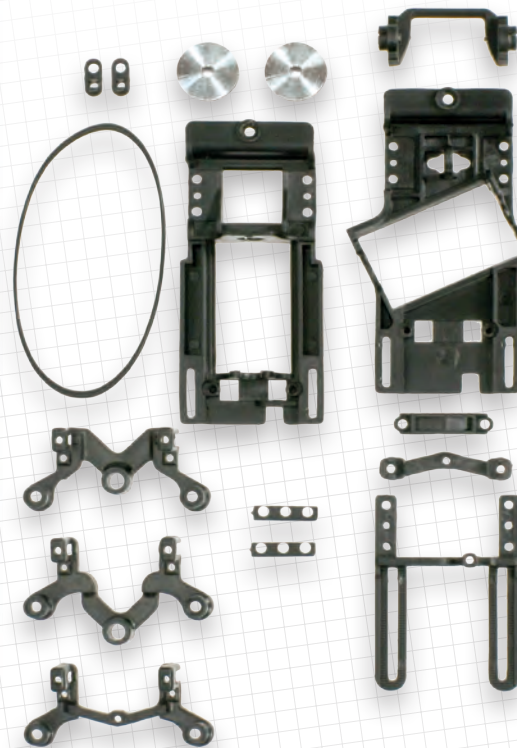

SC-5135

Universal body mount for Montecarlo in-line + anglewinder.

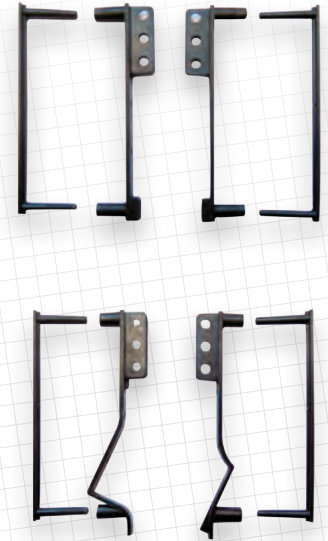

SC-5131

Spring sets for SC-6900 Montecarlo chassis.

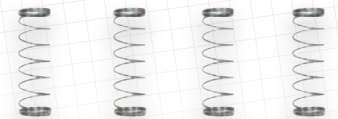

SC-6902

Dakar adjustable chassis assembled with shock absorbers.

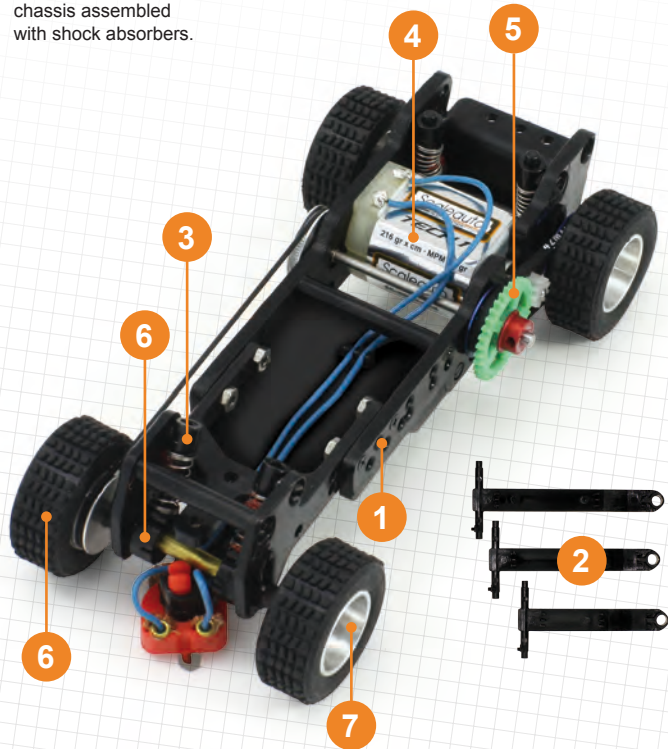

Technical Specifications

1. 2 pieces adjustable wheelbase chassis.
2. Different length swing arm, adjustable stroke and position.
3. Independent shock absorbers with large extension.
4. Sidewinder motor position.
5. 4WD transmission through central axis, pulleys and belts.
6. Off-Road tires.
7. Aluminum rims.
8. 2 chasis position to fix the shock absorbers allow 2 different hardness.
9. Self centered bushing on the axles.
10. Separate axle housing allow metal replacement for lifetime.
11. Swing arm tension adjustment.
12. Magnet option

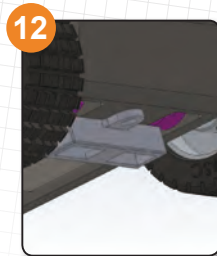
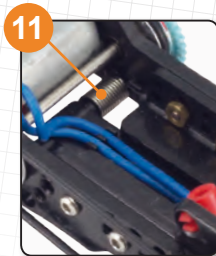
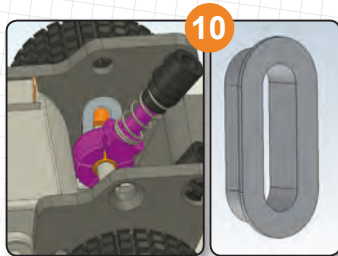

Dakar Chassis 4WD

This brand new chassis was designed from scratch to fulfill the highest expectations of the die hard raid slot driver. Reliability, performance and resistance are the right words to describe the new member in our chassis family that will empower the Raid cars from our catalog.

Built with injected plastic, the Dakar chassis gives to the user a wide range of configuration possibilities supported by a large base of spare accessories.

SC-6903

Dakar adjustable basic chassis kit.

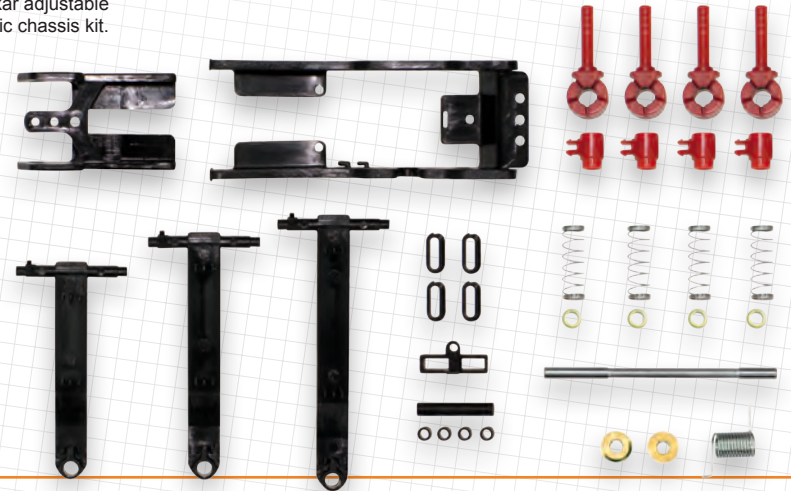

SC-5133a

Springs · standard

SC-5133b

Springs · soft

SC-5133c

Springs · short version

SC-5132

Shock absorbers set.



R

NEW

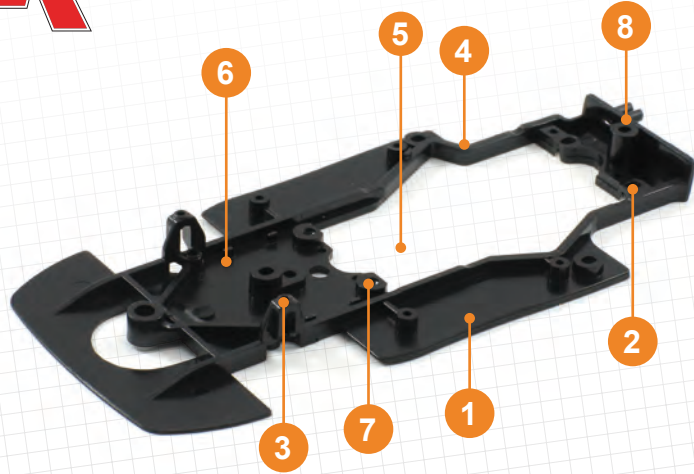

Car Model	Hard	Medium	Soft
HSV-010	SC-6632a	SC-6632b	SC-6632c
BMW Z4	SC-6634a	SC-6634b	SC-6634c
Spyker C8	SC-6635a	SC-6635b	SC-6635c
BMW M1 Gr.5	SC-6636a	SC-6636b	SC-6636c
De Tomaso Pantera Gr.3	SC-6637a	SC-6637b	SC-6637c
SRT Viper GTS-R	SC-6638a	SC-6638b	SC-6638c
Porsche 935 Gr. 5	SC-6639a	SC-6639b	SC-6639c
Porsche 991	SC-6640a	SC-6640b	SC-6640c
Subaru WRC	SC-6641a	SC-6641b	SC-6641c
Peugeot 208	SC-6642a	SC-6642b	SC-6642c
Porsche Carrera RS-RSR	SC-6643a	SC-6643b	SC-6643c
959-Metro	SC-6647a	SC-6647b	SC-6647c

Technical Specifications

1. Plastic injected chasis.
2. Independent motor mount with suspension system allowed.
3. Front Axle height adjustment.
4. Accurate Thickness for race purpose.
5. Allows Sidewinder, Inline and Anglewinder RT3 motor mounts.
6. Integral wire fixing clips.
7. Body floating adjustment system optionally assembled.
8. RT3 compatible body mount fixing.

HS

Technical Specifications

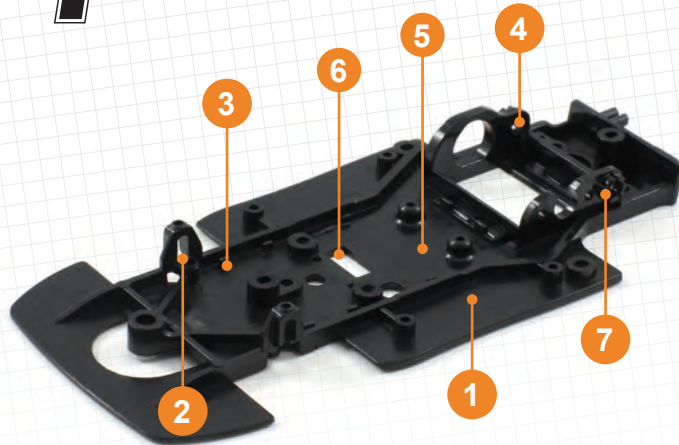

1. Plastic injected 1 sole piece chasis.
2. Front Axle height adjustment.
3. Integral wire fixing clips.
4. Body floating adjustment system optionally assembled.
5. RT3 compatible body mount fixing.
6. Ready compatible for Slot. it Oxigen, SSD and carrera digital chips.
7. Self centered rear axle bronze bushing.

RT2

NEW

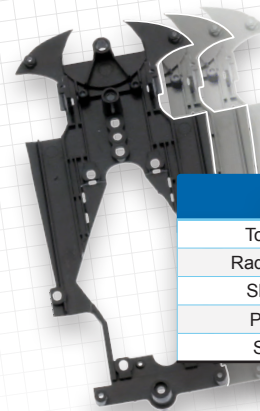

Car Model	Hard	Medium	Soft
Toyota GT One	SC-6605		
Radical SR-9 RT-2	SC-6612a2	SC-6612b2	SC-6612c2
SLS AMG GT3	SC-6613a	SC-6613b	SC-6613c
Pagani Zonda	SC-6621a	SC-6621b	SC-6621c
Subaru WRC	SC-6648a	SC-6648b	SC-6648c

Motor mounts

SC-6522
RT3 Motor mount offset 0,5 mm Side-winder. **Rev3** (new rear bushings)

SC-6526
RT3 Motor mount offset 0,0 mm Side-winder. **Rev3** (new rear bushings)

NEW
SC-6528
RT3 motor mount anglewinder offset 0,5 mm.

SC-6524
RT3 motor mount AW offset 0,5 mm. **Rev3** (new rear bushings)

SC-6525a
RT3 motor mount ARMS (carbon fiber) for AW-IL-SW.

SC-6523
RT3 motor mount In-line offset 0,0 mm. **Rev3** (new rear bushings)

SC-6527
RT3 slim motor mount In-line offset 0,5 mm.

NEW

SC-6521
RT2 anglewinder motor mount offset 0,5 mm. **Rev3** (new rear bushings)

SOFT

SC-6521b
HARD

1/32 Hubs



Lightweight Universal

Width	øD1	øD2	Reference
8,5 mm	14,8 mm	12,7 mm	SC-4030f
8,5 mm	15,8 mm	13,6 mm	SC-4031f
10,0 mm	15,8 mm	13,6 mm	SC-4032f
10,0 mm	17,2 mm	15,0 mm	SC-4033f
8,5 mm	17,2 mm	15,0 mm	SC-4034f
10,0 mm	14,8 mm	12,7 mm	SC-4035f
8,5 mm	16,5 mm	14,3 mm	SC-4046f
8,5 mm	16,9 mm	14,7 mm	SC-4048f
8,5 mm	16,2 mm	14,0 mm	SC-4049f
10,0 mm	16,2 mm	14,0 mm	SC-4051f
8,5 mm	17,5 mm	15,3 mm	SC-4052f
8,5 mm	15,5 mm	13,3 mm	SC-4053f
10,0 mm	16,5 mm	14,3 mm	SC-4054f
10,0 mm	17,5 mm	15,3 mm	SC-4062f

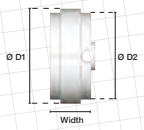

Monza-2 Aluminum

Width	øD1	øD2	Reference
8,5 mm	14,8 mm	12,7 mm	SC-4030d
	15,5 mm	13,3 mm	SC-4053d
	16,2 mm	14,0 mm	SC-4049d
	17,2 mm	15,0 mm	SC-4034d
	17,5 mm	15,3 mm	SC-4052d



Solid Design

Width	øD1	øD2	Reference
8,0 mm	15,0 mm	12,8 mm	SC-4063a
10,0 mm	15,0 mm	12,8 mm	SC-4065a NEW
5,6 mm	15,8 mm	13,7 mm	SC-4067a NEW
6,6 mm	15,8 mm	13,7 mm	SC-4068a NEW
8,5 mm	15,8 mm	13,4 mm	SC-4031a
10 mm	15,8 mm	13,4 mm	SC-4032a
8,5 mm	16,9 mm	14,7 mm	SC-4048a
8,5 mm	17,5 mm	15,3 mm	SC-4052a
11,0 mm	17,5 mm	15,3 mm	SC-4064a NEW

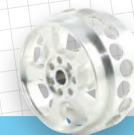

Dakar Design

Width	øD1	øD2	Reference
11,0 mm	20,8 mm	18,6 mm	SC-4075
9,9 mm	19,2 mm	17,0 mm	SC-4076



Monza Magnesium

Width	øD1	øD2	Reference
8,0 mm	16,5 mm	14,3 mm	SC-4046b



Jarama Aluminum Gold Anodized

Width	øD1	øD2	Reference
8,5 mm	15,5 mm	13,3 mm	SC-4053e
	15,8 mm	13,6 mm	SC-4031e
	16,2 mm	14,0 mm	SC-4049e
	16,5 mm	14,3 mm	SC-4046e
	16,9 mm	14,7 mm	SC-4048e
	17,2 mm	15,0 mm	SC-4034e
	17,5 mm	15,3 mm	SC-4052e



Nylon Design

Width	øD1	øD2	Reference
8,5 mm	15,8 mm	13,6 mm	SC-4031y
8,5 mm	16,2 mm	14,0 mm	SC-4049y
8,0 mm	14,5 mm	12,3 mm	SC-4071y
8,0 mm	15,0 mm	12,8 mm	SC-4072y



Plastic Design

Width	øD1	øD2	Reference
7,0 mm	15,8 mm	13,7 mm	SC-4066z



F1

Width	øD1	øD2	Reference
12,5 mm	15,5 mm	13,3 mm	SC-4070f

NEW



Sebring Aluminum Anodized

Width	øD1	øD2	Reference
8,5 mm	14,8 mm	12,7 mm	SC-4030h
	15,5 mm	13,3 mm	SC-4053h
	15,8 mm	13,0 mm	SC-4031h
	16,2 mm	14,0 mm	SC-4049h
	17,2 mm	15,0 mm	SC-4034h
	17,5 mm	15,3 mm	SC-4052h



R+D Team » Tip

Use the new Reamer Tool (SC-5070) to obtain a perfect fit to Scaleauto 3/32" axle.

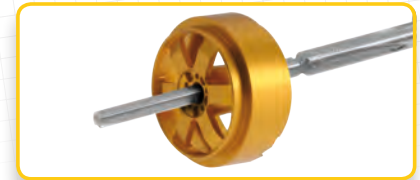

1/32 Hubs family cross chart references



Hub Family Code	øD1	Width	Solid (a)	Magnesium (b)	Monza-2 (d)	Jarama (e)	Ligthweigt (f)	F1 (f)	Sebring (h)	Plastic	Nylon	Dakar
4030	14,8 mm	8,5 mm			✓		✓		✓	✓		
4031	15,8 mm	8,5 mm	✓		✓	✓	✓		✓			
4032	15,8 mm	10,0 mm	✓				✓					
4033	17,2 mm	10,0 mm					✓					
4034	17,2 mm	8,5 mm			✓	✓	✓		✓			
4035	14,8 mm	10,0 mm					✓					
4046	16,5 mm	8,5 mm		✓		✓	✓					
4048	16,9 mm	8,5 mm	✓			✓	✓					
4049	16,2 mm	8,5 mm			✓	✓	✓		✓		✓	
4051	16,2 mm	10,0 mm					✓					
4052	17,5 mm	8,5 mm			✓	✓	✓		✓			
4053	15,5 mm	8,5 mm			✓	✓	✓		✓			
4054	16,5 mm	10,0 mm					✓					
4062	17,5 mm	10,0 mm	✓				✓					
4063	15,0 mm	8,0 mm	✓									
4064	17,5 mm	11,0 mm	✓									
4065	15,0 mm	10,0 mm	✓									
4066	15,8 mm	7,0 mm					✓			✓		
4067	15,8 mm	5,6 mm	✓									
4068	15,8 mm	6,6 mm	✓									
4070	15,5 mm	12,5 mm						✓				
4071	14,5 mm	8,0 mm					✓				✓	
4072	15,0 mm	8,0 mm					✓				✓	
4075	20,8 mm	11,0 mm					✓					✓
4076	19,2 mm	9,9 mm					✓					✓

Aluminum / Carbon Motor Mounts

SC-3004b

PRO RT sidewinder aluminum motor mount for NSR classic.

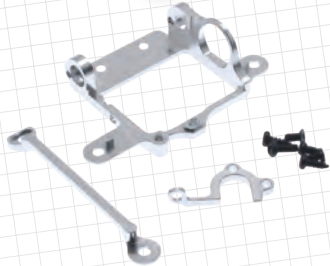
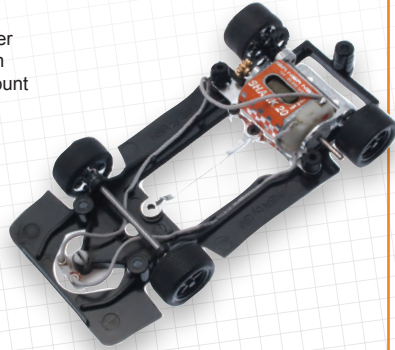

Updated Design

- » Perfect CNC aluminum motor mounts.
- » Ultra light design for minimum weight and maximum speed
- » Interchangeable motor mount with or without offset set inline gears.
- » Optional high speed ball bearing (SC-1312)

SC-3000b

PRO RT In-line aluminum. Compatible with:

- Scaleauto
- MSC
- Slot.it
- Racer
- Sideways
- Arrow Slot

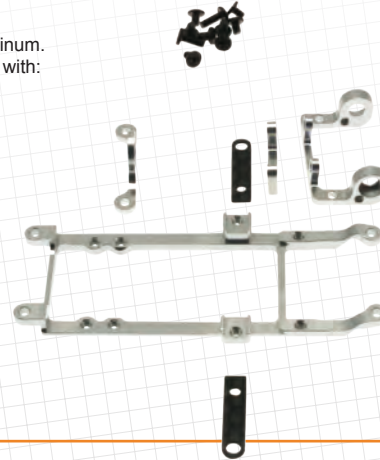

SC-9001

Classic race water slide decals set.



SC-9002

Official Scaleauto decals.



SC-3050

Offset motor mount -0,5 mm.

(Only for reference SC-3000)



SC-3051

Magnet mount for 2 x SC-1502 neodimium magnets. Adjustable height with double screw fixing.

(Only for reference SC-3000)



SC-3051

Carbon fiber arms for aluminum pod in-line SC-3000



SC-9003

Race numbers stickers.



New standard for gear teeth number identification

Scaleauto's gear range is ruled under the new color code that states a unique color to each gear depending on the amount of teeth. Standardization makes tuning experience smoother for the serious Professional Slot Racer.



Use the new reamer Tool (SC-5070) to obtain a perfect fit to Scaleauto 3/32" axle.

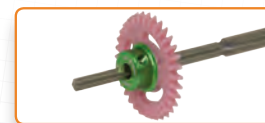

Color / Gear teeth
20 / 30 / 40
21 / 31 / 41
22 / 32 / 42
23 / 33 / 43
24 / 34 / 44
25 / 35 / 45
26 / 36 / 46
27 / 37 / 47
28 / 38 / 48
29 / 39 / 49

NEW Improved with new aluminum hardened insert.

IN-LINE PROCOMP RS

Black Aluminum Insert M2 screw

Image	Teeth / Colour	Ø	Reference
	23 ●	12,8 mm	SC-1109
	24 ●	13,1 mm	SC-1110
	25 ●	13,5 mm	SC-1111
	26 ●	14,1 mm	SC-1112
	27 ●	14,8 mm	SC-1113
	28 ●	15,4 mm	SC-1114
	30 ●	16,2 mm	SC-1100

SIDEWINDER PROCOMP RS

NEW

Blue Aluminum Insert / M2 screw			Red Aluminum Insert / M2 screw		
Ø 17,5 mm			Ø 18,5 mm		
Image	Teeth / Colour	Reference	Image	Teeth / Colour	Reference
	31 ●	SC-1151		33 ●	SC-1143
	32 ●	SC-1152		34 ●	SC-1144
	33 ●	SC-1153		35 ●	SC-1145
	34 ●	SC-1154		36 ●	SC-1146
	35 ●	SC-1155		37 ●	SC-1147
	36 ●	SC-1170			

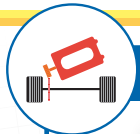

ANGLEWINDER PROCOMP RS (25° motor mounts)

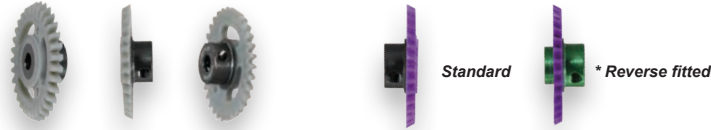

Black Aluminum Insert / M2 screw

Ø 15,8 mm

Green Aluminum Insert / M2 screw

Ø 17,0 mm

Image	Teeth / Colour	Reference
	25 ●	SC-1165
	26 ●	SC-1166
	27 ●	SC-1167
	28 ●	SC-1168
	29 ●	SC-1169
	30 ●	SC-1170

Image	Teeth / Colour	Reference
	31 ●	SC-1171
	31* * Reverse fitted	SC-1171b
	32 ●	SC-1172
	32* * Reverse fitted	SC-1172b

SC-1120a

Axle spacers for 3/32" brass 2 mm.

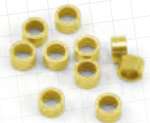

SC-1120c

Axle spacers for 3/32" brass 1 mm.



SC-1120f

Axle spacers for 3/32" steel 0,1 mm.



SC-1121

NEW

Axle spacers for 3/32" plastic 2, 1, 0.1 mm.



Axle accessories

SC-1123

Screw M2 + aluminum stopper.



SC-1124

3/32" Axle stopper light and anodized. M2 screw.

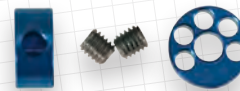

Magnets

SC-5515

NEW

16,4 x 4 x 2,8 mm (RT3 In-Line).

SC-5517

NEW

16,4 x 3,5 x 2,8 mm (RT3 SW - AW).

SC-5518

NEW

16,4 x 2,9 x 3 mm (RT3 Slim In-line).

SC-5519

14,5 x 3,9 x 1,8 mm Neodimium magnet RT2 AW squared.

SC-5516

NEW

8 x 4 mm (RT3).



Motor mount suspension system

SC-5128a

Motor mount shock absorber kit long.



SC-5128b

Motor mount shock absorber kit short.

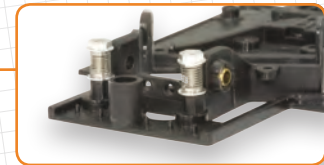

Usable in RT2 and RT3 motor mounts as well as 3rd party motor mounts

SC-5129a

RT3 Body floating adjustment adapters 3 mm.

SC-5129b

RT3 Body floating adjustment adapters 4 mm.

SC-5129c

RT3 Body floating adjustment adapters 5 mm.

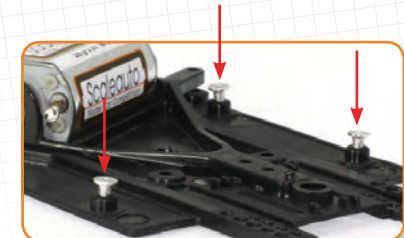

Body Kits and Body Spares

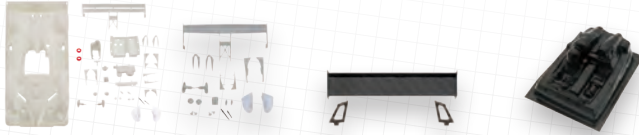

Car Model	Body kit	Body spare pieces	Rear wing (Rubber + Carbon fiber)	Complete light cockpit and clear pieces
Tofota GT-One (white)				SC-6602
Toyota GT-One painted body (red)	SC-3600b			SC-6602
Radical SR-9	SC-3601	SC-3601b		SC-6611
Mercedes Benz SLS GT3 (white)	SC-3602	SC-3602b	SC-3602c	SC-6614
HSV-010	SC-3603	SC-3603b	SC-3603c	SC-6617
BMW Z4 GT3	SC-3604	SC-3604b	SC-3604c	SC-6618 / SC-6618b (rally)
Spyker C8 GT2-R	SC-3605			SC-6619
Pagani Zonda	SC-3606	SC-3606b	SC-3606c	SC-6620
M1 Gr.5	SC-3608			SC-6624
DeTomaso Pantera	SC-3609			SC-6625 / SC-6625b (rally resine set)
SRT Viper GTS-R	SC-3610			SC-6626
Porsche 935	SC-3611			SC-6627
Porsche 991	SC-3612			SC-6630
Subaru WRC	SC-3613			SC-6631
Porsche 959 Raid	SC-3614			SC-6644
Mini All4 Racing	SC-3615			SC-6645
Peugeot 208	SC-3616			SC-6646
Carrera RSR	SC-3617			SC-6627
Carrera RS	SC-3618			SC-6627
Porsche 935 / 77-J	SC-3619			SC-6627

SC-3607

Rubber mirrors + antenna



Axles



ø (D)	Lenght (L)	Steel	Steel Recessed	Hollow	Carbon	Titanium
2,38 mm	45 mm		SC-1214			
	48 mm		SC-1215			
	50 mm	SC-1210		SC-1201		SC-1230
	53 mm		SC-1216			
	55 mm	SC-1211		SC-1202	SC-1221	
	60 mm	SC-1212				
3 mm	65 mm	SC-1213				
	60 mm	SC-1240			SC-1262	
	65 mm	SC-1241			SC-1263	
	70 mm	SC-1242				
3 mm	75 mm	SC-1243			NEW SC-1624	
	65 mm	SC-1241b	Specially for ceramic Ball Bearing superfine adjustment (SC-1335)			
	70 mm	SC-1242b				

Rubber tires for profile hubs.

Width	øD1	øD2	Type Hardness				
			Standard	Zero Grip	RT	Medium	Soft
8,0 mm	15,8 mm	13,0 mm		SC-4743	SC-4742		
8,5 mm	16,0 mm	14,0 mm		SC-4724	SC-4738		
10,0 mm	17,5 mm	16,0 mm		SC-4723			
9,0 mm	18,0 mm	14,5 mm	SC-4746		SC-4734	SC-4739	
10,0 mm	18,5 mm	15,0 mm	SC-4718				
10,0 mm	19,0 mm	14,0 mm			SC-4720		SC-4726
10,5 mm	19,0 mm	15,0 mm			SC-4733		
8,8 mm	19,5 mm	15,0 mm	SC-4719				
9,5 mm	19,5 mm	15,0 mm	SC-4747		SC-4735	SC-4740	
9,5 mm	20,0 mm	15,0 mm				SC-4741	
10,0 mm	20,0 mm	15,8 mm	SC-4744				
10,0 mm	20,0 mm	16,9 mm			SC-4722		SC-4728
12,0 mm	20,0 mm	14,0 mm			SC-4721		SC-4727
7,5 mm	21,0 mm	15,0 mm	SC-4748				
11,0 mm	22,0 mm	18,0 mm	SC-4745				

Rubber tires for 1/32

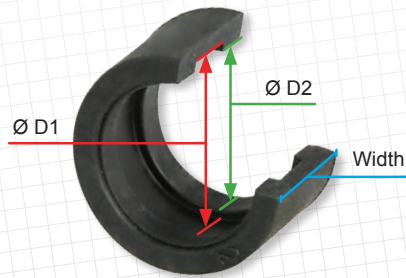

Size and brand name is engraved on the side of all tires for a quick simple identification.

Surface type:

- Slick:** For race track purposes
- Stripped:** For modern road cars replicas
- Classic:** For classic road cars replicas
- Raid:** For Off-Road racing.

Hardness compounds:

- Standard:** Used in the original cars starting from 2014 year • *Ninco - Scalextric - SCX*
- Zero Grip:** Minimum friction surface for front wheels only
- RT:** Harder with higher grip • *Ninco - Scalextric - SCX*
- Medium:** Intermediate Grip • *Carrera - Wood - Ninco*
- Soft:** Softer with high grip for smooth surfaces • *Scalextric Sport - Carrera (glued to hubs only)*

1/32 rubber tires compatibility cross reference chart

Hub Family code	D1 Diameter	Width	Standard	Zero Grip	RT	Medium	Soft
4030	14,8 mm	8,5 mm	SC-4746 / SC-4719	SC-4743 / SC-4724	SC-4742 / SC-4738 SC-4734 / SC-4720	SC-4739	SC-4726
4031	15,8 mm	8,5 mm	SC-4746 / SC-4719	SC-4743 / SC-4724	SC-4742 / SC-4738 SC-4734 / SC-4720 SC-4733 / SC-4735	SC-4739 / SC-4740 SC-4741	SC-4726
4032	15,8 mm	10,0 mm	SC-4718 / SC-4747 SC-4744	SC-4732	SC-4735 / SC-4721	SC-4740	SC-4727
4033	17,2 mm	10,0 mm	SC-4718 / SC-4747 SC-4744 / SC-4745		SC-4735 / SC-4722	SC-4740	SC-4728
4034	17,2 mm	8,5 mm	SC-4719		SC-4734 / SC-4733 SC-4735	SC-4739 / SC-4740 SC-4741	
4035	14,8 mm	10,0 mm	SC-4718 / SC-4747	SC-4723	SC-4721		SC-4727
4046	16,5 mm	8,5 mm	SC-4746 / SC-4719		SC-4734 / SC-4720 SC-4733 / SC-4735	SC-4739 / SC-4740 SC-4741	SC-4726
4048	16,9 mm	8,5 mm	SC-4746 / SC-4719		SC-4734 / SC-4720 SC-4733 / SC-4735	SC-4739 / SC-4740 SC-4741	SC-4726
4049	16,2 mm	8,5 mm	SC-4746 / SC-4719		SC-4734 / SC-4720 SC-4733 / SC-4735	SC-4739 / SC-4740 SC-4741	SC-4726
4051	16,2 mm	10,0 mm	SC-4718 / SC-4747 SC-4744	SC-4723	SC-4735 / SC-4721	SC-4740	SC-4727
4052	17,5 mm	8,5 mm	SC-4719		SC-4734 / SC-4735	SC-4739 / SC-4740 SC-4741	
4053	15,5 mm	8,5 mm	SC-4746 / SC-4719	SC-4743 / SC-4724	SC-4742 / SC-4738 SC-4734 / SC-4720 SC-4733 / SC-4735	SC-4739 / SC-4740 SC-4741	SC-4726
4054	16,5 mm	10,0 mm	SC-4718 / SC-4747 SC-4744	SC-4723	SC-4735 / SC-4721	SC-4740	SC-4727
4062	17,5 mm	10,0 mm	SC-4718 / SC-4747 SC-4744 / SC-4745		SC-4735 / SC-4722	SC-4740	SC-4728
4063	15,0 mm	8,0 mm	SC-4746 / SC-4719	SC-4743 / SC-4724	SC-4742 / SC-4738 SC-4734 / SC-4720 SC-4733	SC-4739 / SC-4741	SC-4726
4064	17,5 mm	11,0 mm	SC-4745				
4065	15,0 mm	10,0 mm	SC-4718 / SC-4744 SC-4747	SC-4723	SC-4735 / SC-4721	SC-4740w	SC-4727
4067	15,8 mm	5,6 mm	SC-4748				
4068	15,8 mm	6,6 mm	SC-4748	SC-4732			

Pinions M50 for 2mm motor shaft (2 units each pack)

Aluminum				Steel				Brass			
	Diameter	Teeth	Reference		Diameter	Teeth	Reference		Diameter	Teeth	Reference
	4,5 mm	7	SC-1027		4,5 mm	7	SC-1127		4,5 mm	7	SC-1190
	5,4 mm	8	SC-1028		5,4 mm	8	SC-1128		5,4 mm	8	SC-1191
	5,8 mm	9	SC-1029		5,8 mm	9	SC-1129		5,8 mm	9	SC-1192
	6,35 mm	10	SC-1030		6,35 mm	10	SC-1130		6,35 mm	10	SC-1193
	6,75 mm	11	SC-1031		6,75 mm	11	SC-1131		6,75 mm	11	SC-1194
	7,25 mm	12	SC-1032		7,25 mm	12	SC-1132		7,25 mm	12	SC-1195
	7,75 mm	13	SC-1033		7,75 mm	13	SC-1133		7,75 mm	13	SC-1196
	8,25 mm	14	SC-1034		8,25 mm	14	SC-1134		8,25 mm	14	SC-1197
	8,7 mm	15	SC-1035		8,7 mm	15	SC-1135		8,7 mm	15	SC-1198

Ø 6,50 mm

SC-1070

NEW

Brass pinion M50 for 2mm. With M2 fixing screw. **10 tooth.**

SC-1071

Brass pinion M50 for 2mm. With M2 fixing screw. **11 tooth.**

SC-1072

Brass pinion M50 for 2mm. With M2 fixing screw. **12 tooth.**

Ø 6,75 mm

SC-1073

NEW

Brass Pinion M50 for 2mm. With M2 fixing screw. **13 tooth.**

Plastic nylon press-on pinions

SC-1005b

Nylon M50 set teeth (8' 9' 10' 11' 12' 13' 14' 15')

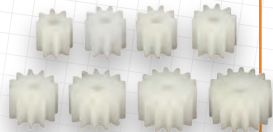

Nylon (4 units)	Teeth	Reference
	8	SC-1008
	9	SC-1009
	10	SC-1010
	11	SC-1011

Nylon (4 units)	Teeth	Reference
	12	SC-1012
	13	SC-1013
	14	SC-1014
	15	SC-1015

SC-1292

Nylon 1,50 mm M50 set 9 teeth.

NEW



Ø 7,50 mm

SC-1082

NEW

Brass Pinion M50 for 2mm. With M2 fixing screw. **12 tooth.**

SC-1083

Brass Pinion M50 for 2mm. With M2 fixing screw. **13 tooth.**

Guides and Accessories

Adjustable Universal Guide

SC-1603

Universal guide 8,3* mm blade with adjustable spacers and ø3,75 mm stick.

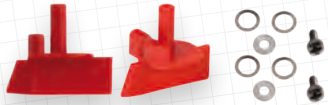

SC-1604

Universal guide 7* mm blade with adjustable spacers and ø3,75 mm stick.

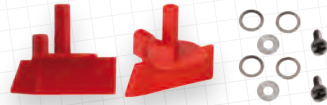

SC-1607

Universal guide 8,3* mm blade with adjustable spacers and ø3,4 mm stick.



SC-1608

Universal guide 7* mm blade with adjustable spacers and ø3,4 mm stick.

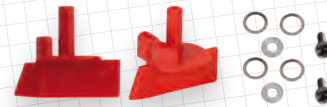

Home Set Guides

SC-1605

Clip-in race blade profile guide 7 mm.

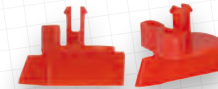

SC-1606

Clip-in race blade profile guide 7 mm with active suspension.

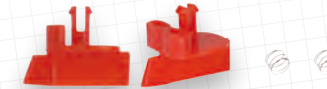

SC-1620

Clip-in home rally guide 7 mm.



SC-1621

Clip-in home rally guide 7 mm with active suspension.



7 mm blades are useable for commercial home set plastic tracks.

8,3 mm blades are useable for Carrera Evolution or wooden tracks.

Wires and braids

SC-1610

Red silicone wire 1 m length. ø 1,3 mm.



SC-1611

Black silicone wire 1 m length. ø 1,3 mm.



SC-1633

Blue silicone wire 1 m length. ø 1,3 mm.



SC-1625

Blue silicone wire 1 m length. ø 0,9 mm.



SC-1627

White silicone wire 1 m length. ø 2 mm.



SC-1625

Guide terminals for 1/32 slot cars.



SC-1612

Universal soft braids.

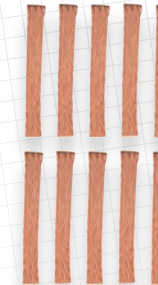

SC-1613

Universal standard braids.

SC-1636

Super thin soft braids 7 cm cooper.

SC-1630

Superthin tinned braid 3,0 x 0,3 mm. 1m length.

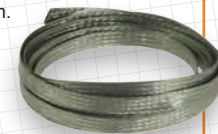

SC-1631

Superthin tinned braid 3,5 x 0,5 mm 1m length.



Friction pulley and belts

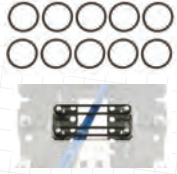

Friction belts	
Reference	Description
SC-1700a	Friction belt 1,2 x 55 mm
SC-1700b	Friction belt 1 x 58 mm
SC-1700c	Friction belt 1 x 10 mm for chassis wire fixing.

Traction belts					
Teeth	42	43	63	65	67
1,5 mm Thickness	SC-1720a42	SC-1720a43	SC-1720a63	SC-1720a65	SC-1720a67



Traction belts								
Teeth	76	78	80	82	85	87	93	94
1,5 mm Thickness	SC-1720a44	SC-1720a63	SC-1720a65	SC-1720a67	SC-1720a85	SC-1720a87	SC-1720a93	SC-1720a94

Traction belts								
Teeth	95	106	110	112	114	115	118	120
1,5 mm Thickness	SC-1720a95	SC-1720a106	SC-1720a110	SC-1720a112	SC-1720a114	SC-1720a115	SC-1720a118	SC-1720a120

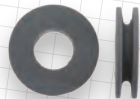

Rubber friction pulleys	
Reference	Description
SC-1701a	Int. 8 mm Ext. 15,5 mm (needs aluminum insert SC-1705 or SC-1706).
SC-1701b	Int. 9 mm Ext. 12 mm (needs aluminum insert SC-1705 or SC-1706).
SC-1701c	Int. 10 mm Ext. 15,5 mm (needs aluminum insert SC-1705 or SC-1706).
SC-1701d	Int. 13 mm Ext. 15,5 mm (needs aluminum insert SC-1705 or SC-1706).

Aluminum friction pulleys				
ø	12 mm Solid design	6,5 mm	8,0 mm	10,0 mm
3/32"	SC-1702a	SC-1703a	SC-1703b	SC-1703c
3 mm	SC-1702b	SC-1704a	SC-1704b	SC-1704c



Axle stoppers	
Reference	Description
SC-1705	3/32" Axle stopper. Rubber pulley insert M2 screw set.
SC-1706	3 mm Axle stopper. Rubber pulley insert M2 screw set.

Anodized aluminum traction pulleys								
Teeth	11	12	13	14	15	16	17	18
3/32"	SC-1721a	SC-1722a	SC-1723a	SC-1724a	SC-1725a	SC-1726a	SC-1727a	SC-1728a
3 mm	SC-1721b	SC-1722b	SC-1723b	SC-1724b	SC-1725b	SC-1726b		

Screw sets

SC-5124

Steel allen head screw
M2 x 4 mm. (10 units)



SC-5125

Steel allen rounded
head screw. (10 units)
M2 x 3 mm.
M2 x 4 mm.
M2 x 6 mm.
M2 x 8 mm.
M2 x 10 mm.



SC-5126

Steel allen rounded
head M2 x 4 mm
screw. (10 units)



SC-5105

Phillips steel screw
conic head MS x 8
mm. (10 units)

SC-5123

M2 x 4' 6' 8' 10' 12'



SC-5119

Assorted srew set.
(10 units)



SC-5104

Phillips steel screw.
(10 units)



SC-5109

Allen screw M2 x
2 mm. (10 units)



SC-5124

Steel allen crew M2 x
3 mm. (10 units)



SC-5111

Allen inox screw M2
x 6 mm Hubs / Gear.
(10 units)

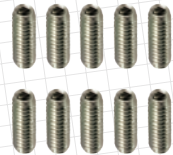

SC-5112

Allen inox screw M3
x 3 mm Hubs / Gear.
(10 units)



SC-5117

Titanium allen screw
M2 x 6 mm. (10 units)



SC-5120

Countersunk M2
Titanium screws.
(20 units)
4 x M2 x 4 mm.
M2 x 6 mm.
M2 x 8 mm.
M2 x 10 mm.
M2 x 12 mm.



SC-5121

Flat M2 Titanium
screws. (20 units)
4 x M2 x 2 mm.
M2 x 4 mm.
M2 x 6 mm.
M2 x 8 mm.
M2 x 10 mm.



SC-5122

Half thread M2
Titanium screws.
(6 units)
2 x M2 x 8 mm.
M2 x 10 mm.
M2 x 12 mm.



SC-5127

Half thread M2 Brass
screws. (6 units)
2 x M2 x 8
M2 x 10
M2 x 12



SC-5106

Flat nylon screw
M2 x 10 (10 units)

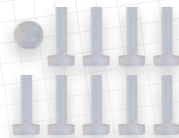

SC-5100

Selfblocking nuts
M2 x 4,5 mm.
(10 units)



SC-5101

M2 inox hardened
nuts. (10 units)

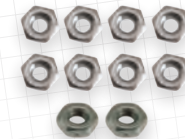

SC-5118

Selfblocking nuts
M2 x 4 mm.
(10 units)



SC-5103

Inox M2 self blocking
spacers. (10 units)





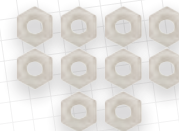

SC-5102

M2 nylon nuts.
(10 units)



Motors	Tech 1 • 20.000 r.p.m.	Tech 2 • 25.000 r.p.m.	Tech 3 • 30.000 r.p.m.	Outlaw 30.000 r.p.m.
Type S-CAN Tested at 12V Size: 25x20x15 mm Double shaft Plastic endbell 2 mm axle	 SC-08b • 4,5 gr  0,21 Amp • 216 gr x cm	 SC-09b • 4,5 gr  0,18 Amp • 225 gr x cm	 SC-10b • 4,5 gr  0,32 Amp • 206 gr x cm	 SC-06 • 5,5 gr  0,30 Amp • 160 gr x cm
Type LONG-CAN Tested at 12V Size: 32,1x20,2x15,3 mm Sealed endbell 2 mm axle	 SC-11b • 5 gr  0,18 Amp • 285 gr x cm	 SC-12b • 5 gr  0,35 Amp • 285 gr x cm	 SC-13 • 9,5 gr  0,32 Amp • 330 gr x cm	
Type SHORT-CAN Tested at 12V Size: 25x20x15 mm Sealed endbell 2 mm axle	 SC-14b • 4,5 gr  0,20 Amp • 205 gr x cm	 SC-15b • 4,5 gr  0,18 Amp • 225 gr x cm	 SC-16b • 4,5 gr  0,37 Amp • 254 gr x cm	

	Sprinter Junior 18.000 r.p.m.
	 SC-27b • 14,5 gr  0,22 Amp • 310 gr x cm
Type LONG-CAN Tested at 12V Size: 32,1x20,2x15,3 mm Sealed endbell 2 mm axle	Endurance  SC-26 • 4 gr  0,20 Amp • 318 gr x cm

	Sprinter 2 21.500 r.p.m.	Sprinter 22.000 r.p.m.	Sprinter 4WD 22.000 r.p.m.
Type LONG-CAN Tested at 12V Size: 32,1x20,2x15,3 mm Sealed endbell 2 mm axle	 SC-25b • 14,5 gr  0,28 Amp • 300 gr x cm	 SC-25c • 14,5 gr  0,28 Amp • 300 gr x cm	 SC-25d • 14,5 gr  0,28 Amp • 300 gr x cm

Bushing and Bearings

Bronze and nylon bushing					
	SC-1354 Bronze 5 x 2mm Not flanged.		SC-1351 Bronze 5mm x 3/32" Flanged.		SC-1357 Bronze 6mm x 3/32" Flanged.
	SC-1358 Bronze 6mm x 3/32" Double flanged.		SC-1352b Nylon 5mm x 3/32" Double flanged.		SC-1362b Nylon 5mm x 3/32" Triple flanged.
	SC-1325 Nylon 5mm x 3/32" Double flanged. Bronze insert.		SC-1355 Aluminum 5mm x 3/32" Double flanged. Bronze insert		SC-1353 Nylon 5mm x 3/32" Double flanged. Excentric axle hole.

High quality ceramic ball bearing			
	SC-1328 5mm x 3/32" Open wall. Flanged. For 3/32" Axle.		SC-1335 6 x 3mm Open wall. Flanged. For 3/32" Axle.

High quality ball bearing	
	SC-1334 6,35mm x 1/8" Flanged. For 1/8" Axle.

Espheric ball bearing	
	SC-1359 NEW 3,75mm x 3/32" x 2 mm

High quality steel ball bearing 3mm Axle					
	SC-1330 6 x 3 mm Not flanged.		SC-1331 6 x 3 mm Flanged.		SC-1333 6 x 3 mm Open wall. Flanged.

High quality steel bearing 3/32" Axle					
	SC-1319 4,75 mm x 3/32" Not flanged.		SC-1320 4,75mm x 3/32" Flanged. Open wall.		SC-1323 5mm x 3/32" Double flanged. Width 2mm
	SC-1321 5 mm x 3/32" Not flanged.		SC-1322 NEW 5mm x 3/32" Flanged. Width 2,5 mm.		SC-1324 5mm x 3/32" Double flanged. Width 1,7mm.
			SC-1329 6mm x 3/32" Flanged.		

High Performance Sponge Wheels



Hardcomp
Zero grip sponge
for front wheels only.



Procomp
Soft high grip sponge, specially
for cold or low grip tracks.
Short life.

3/32" Axle



Width	D1	D2	Procomp	Procomp 2	Procomp 3	Hardcomp
9,0 mm	20,5 mm	15,0 mm				SC-2717p
9,0 mm	19,0 mm				SC-2019	
9,0 mm	20,5 mm				SC-2018	
11,0 mm	20,5 mm		SC-2007	SC-2008	SC-2009	

2,5 Axle



Width	D1	D2	Procomp	Procomp 2	Procomp 3	Hardcomp
20,0 mm	20,5 mm	11,0 mm	SC-2002			

1/8" Axle



Width	D1	D2	Procomp	Procomp 2	Procomp 3	Hardcomp
20,0 mm	20,5 mm	11,0 mm	SC-2321			

3mm Axle Black Series



Width	D1	D2	Procomp	Procomp 2	Procomp 3	Procomp 4	Hardcomp
13,0 mm	25,5 mm	21,0 mm		SC-2620pbb	SC-2421pbb	SC-2521pbb	

3 mm Axle



Sponge tires are
supplied in bags of 2
units with screws.

Width	D1	D2	Procomp	Procomp 2	Procomp 3	Procomp 4	Hardcomp
6,0 mm	25,5 mm	21,0 mm					SC-2723p

8,0 mm	22,5 mm	17,0 mm					SC-2718p
	23,5 mm	19,0 mm		SC-2623p			
	24,5 mm	19,0 mm					SC-2720p
	24,5 mm	21,0mm					SC-2719p
	25,2 mm	21,0 mm					SC-2710p
	25,5 mm	17,0 mm					SC-2701p
	23,5 mm	19,0 mm					SC-2722p
	25,5 mm	19,0 mm					SC-2721p
	25,5 mm	21,0 mm		SC-2606p			SC-2720p
	26,5 mm	21,0 mm					SC-2715p
27,5 mm	21,0 mm					SC-2709p	



Procomp 2

Medium high grip sponge, with special grip for plastic track.



Procomp 3

Hard high grip sponge, special for wooden tracks or high grip. Perfect for endurance races.



Procomp 4

Highest quality sponge tyre for smooth race on high grip wooden tracks.

Fluorescent paint

3 mm Axle



Width	D1	D2	Procomp	Procomp 2	Procomp 3	Procomp 4	Hardcomp
11,0 mm	20,5 mm	11,0 mm	SC-2010	SC-2011			
	20,5 mm	15,0 mm		SC-2013	SC-2014		SC-2713p
	22,5 mm	15,0 mm	SC-2015	SC-2016			
	22,5 mm	17,0 mm			SC-2409p		
	25,5 mm	21,0 mm	SC-2119p		SC-2419p		



Width	D1	D2	Procomp	Procomp 2	Procomp 3	Procomp 4	Hardcomp
16,0 mm	24,5 mm	19,0 mm				SC-2537p	
	25,5 mm	17,0 mm	SC-2114p		SC-2414p		
	25,5 mm	19,0 mm				SC-2538p	
	25,5 mm	21,0 mm				SC-2515p	
	26,5 mm	21,0 mm				SC-2516p	
	27,5 mm	21,0 mm		SC-2624p	SC-2424p		



Width	D1	D2	Procomp	Procomp 2	Procomp 3	Procomp 4	Hardcomp
13,0 mm	23,5 mm	17,0 mm					
	24,5 mm	17,0 mm			SC-2405p		
	24,5 mm	19,0 mm		SC-2634p		SC-2534p	
	25,0 mm	17,0 mm					
	25,5 mm	17,0 mm	SC-2110p	SC-2610p	SC-2410p		
	25,5 mm	19,0 mm			SC-2436p		
	25,5 mm	21,0 mm		SC-2620p	SC-2420p	SC-2520p	
	26,5 mm	21,0 mm			SC-2425p	SC-2525p	
	26,7 mm	17,0 mm			SC-2407p		
	27,5 mm	17,0 mm			SC-2411p		
	27,5 mm	21,0 mm	SC-2121p	SC-2621p	SC-2421p	SC-2521p	



Width	D1	D2	Procomp	Procomp 2	Procomp 3	Procomp 4	Hardcomp
18,0 mm	2,5 mm	17,0 mm	SC-2112p				
	27,5 mm	17,0 mm					
	27,5 mm	21,0 mm		SC-2623p			



Width	D1	D2	Procomp	Procomp 2	Procomp 3	Hardcomp
11 mm	26,5 mm	21,2 mm				SC-2724brm
16 mm	28 mm	21,2 mm			SC-2426brm	

SC-5072

New Features in this Evo2 truing machine

- » Super fine tuning for the rectifying head
- » Adjustable parallelism between rectifying axle and drum axle.
- » Clear view of the wheel diameter
- » Strong and solid assembled structure



1. Complete vacuum box for dirt storage and protection
2. Optical sanding measure view
3. High quality ball bearings
4. Allow to do up to 2 tires simultaneously to perfectly pair sets of tires. Easy exchangeable multiple grain abrasive drum
5. Smooth 5 pole motor
6. Preassembled electronic speed regulator
7. Only needs 3 Amp to work
8. Anodized aluminum CNC machined core design for a perfect alignment
9. Vacuum cleaner Fixing Hole
10. Up to 30 mm diameter tires allowed
11. Easy to disassemble for adjusting and replacing sanding drums, belts and cleaning
12. For all types of available axles (3mm, 3/32")
13. Maximum sanding stopper

Spare parts for tyre Truing Machine

SC-5073a

Abrasive drum
80 gritt. (1 unit)

SC-5073b

Abrasive drum
120 gritt. (1 unit)

SC-5073z

Rubber belts.
(5 pairs)

SC-5040g

Aluminum
core drum for
SC-5040 (Evo1
Tyre Truing).

SC-5040f

Vacuum connector.
Valid for SC-5040
and SC-5072 Tyre
truer.



Storage and Carrying

SC-5071

Slotbox Professional series 1.
(60 x 30 x 40 cm).

NEW

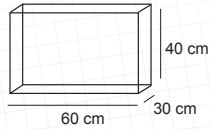

Technical Specifications

1. Tiltable handle holds up to 30kg (66lbs)
2. 2 drawers with telescopic guides (height 80mm)
3. Elastic strip holder for tools
4. Transparent spacers and shelves
5. Flexible shelf configuration with 20mm separation mounting slots
6. Shock resistant external composite with rounded corners

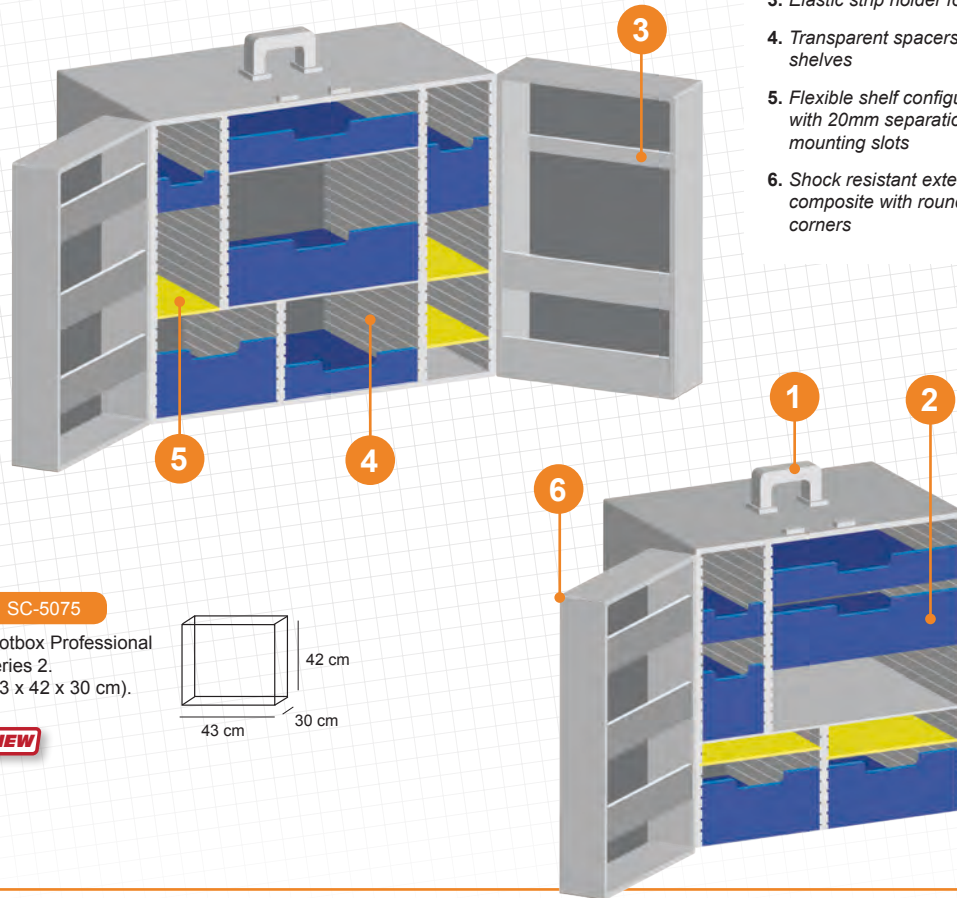

SC-5075

Slotbox Professional series 2.
(43 x 42 x 30 cm).

NEW

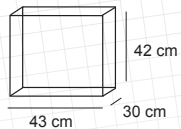

Slotbox Accessories

NEW

SC-5076a

Drawer type A for Slotbox.
(300 x 80 mm).



SC-5076b

Drawer type B for Slotbox.
(200 x 80 mm).



SC-5076c

Drawer type C for Slotbox.
(100 x 80 mm).



SC-5077a

Drawer type A for Slotbox.
(300 x 40 mm).

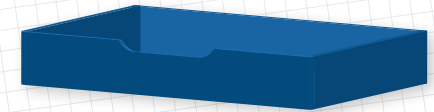

SC-5077b

Drawer type A for Slotbox.
(200 x 40 mm).

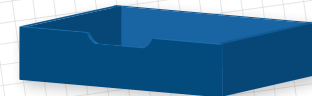

SC-5077c

Drawer type A for Slotbox.
(100 x 40 mm).



SC-5078a

Shelf type A for Slotbox.
(300 mm).



SC-5078b

Shelf type B for Slotbox.
(200 mm).



SC-5078c

Shelf type C for Slotbox.
(100 mm).



SC-5053

Aluminum Slot Box car transport
(37 x 25 x 16 cm).

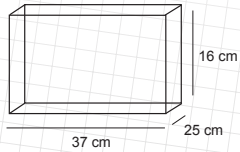

SC-5054

Aluminum controller box
(30 x 30 x 7 cm)

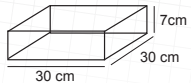

SC-5050

Aluminum modular Slot Box with wheels
(37 x 25 x 80 cm).

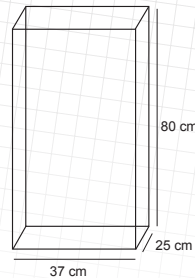

NEW

- Hinge materials
- External harder materials
- Stronger ribbets



New improvements

Four 360° wheels



Stronger ribbets



Harder material



Boxes

SC-5055c

Small box
container,
21 x 30 mm
(10 pieces)

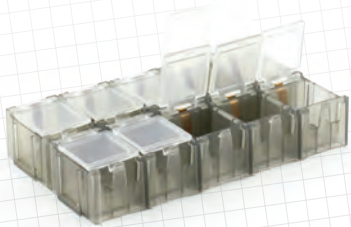

SC-5055b

Medium box
container,
70 x 30 mm
(6 pieces)

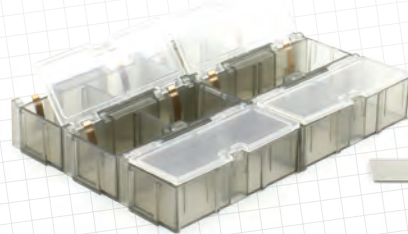

SC-5055c

Large box
container,
70 x 70 mm
(4 pieces)

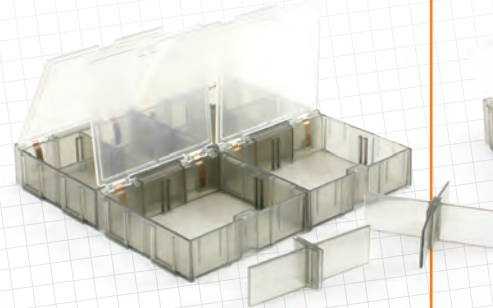

SC-5055c

Combikit boxes.
Contains:
2 x SC-5055a
2 x SC-5055b
6 x SC-5055c

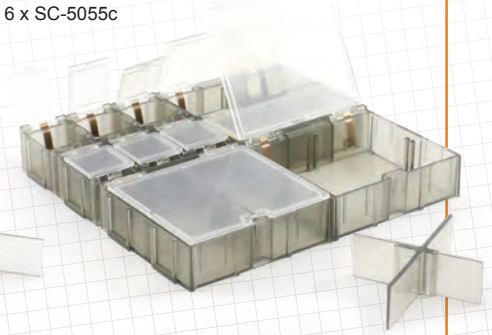

SC-1001

Plastic box for
1/24 car.



SC-1000

Clear collection
box (Cardboard
and car not
included).



Precision Tools



Adjustable torque

Tools	ProTool	ProDyno
	SC-5030 ProTool allen 0,95 mm with blue aluminum handle.	SC-5044 ProDyno wrench allen 0,95 mm
	SC-5038 ProTool allen 1,3 mm with blue aluminum handle.	SC-5045 ProDyno wrench allen 1,3 mm
	SC-5031 ProTool allen 1,5 mm with blue aluminum handle.	SC-5046 ProDyno wrench allen 1,5 mm
	SC-5032 ProTool allen 2 mm with blue aluminum handle.	
	SC-5033 ProTool Phillips screwdriver with blue aluminum handle.	
	SC-5034 ProTool M4 nut with blue aluminum handle.	
	SC-5035 ProTool M4,5 nut with blue aluminum handle.	

Mesure	Long Bit	Short Bit
0,95 mm	SC-5037	SC-5047
1,3 mm	SC-5041	SC-5048
1,5 mm	SC-5036	SC-5049
Flat screw driver	SC-5079	

SC-5070

Reamer for 2mm, 3/32" and 3 mm.



Basic Tools

SC-5024

M1,5 basic allen.

SC-5025

M2,5 basic allen.

SC-5026

M0,95 basic allen.



SC-5074

Abrasive rubber for track cleaning.

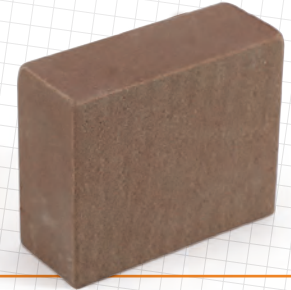

Professional Fluids

SC-5302

Speed oil. Special for bearings and motors 15 ml.



SC-5305

Speed drops 15 mlv.



SC-5300

Sponge and rubber tyre cleaner.



SC-5301

Slotgrip Sponge/ Rubber tyre cleaner.



SC-5304

Speed oil-2. Special for bearings and motors 12 ml.



SC-5303

White magic grease special for gears. 15 ml.



3D PRINT

SLOT FACTORY SERVICE

Scaleauto will provide factory support for 3D print services for own designed slot pieces as well as for customer designed on demand.

This 3D print service opens the range of available pieces for any customer:

- New Chassis developments for Scaleauto and other brands.
- Detailed pieces for slot cars and scenics.
- Special purposed designed pieces for any car, controller, tracks.
- Plastic Injection for high detailed and low production runs.

3D print services provides to our customers to reproduce any designed pieces with a very low cost price. Self made pieces are welcome and new designers can explode its own limits as the 3D prints have very few structural limit requests.

3 different final quality products:

	Definition	Structure	Minimum order
Plastic injection	High	Limited	300
SLA	Medium	Unlimited 0,5 mm acuracity	1
FDM	Low	Unlimited 0,5 mm acuracity	1

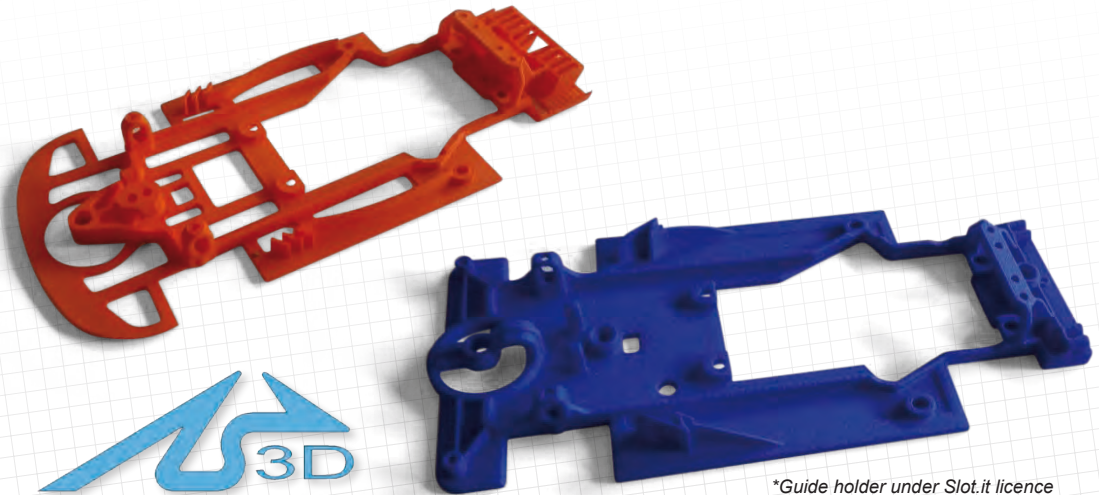

*Guide holder under Slot.it licence

Initial coming soon developments:

SC-6801 Chassis DTM A5
Scalextric
plastic injection
R-version

SC-6802 Chassis DTM C-Klasse
Scalextric
plastic injection
R-version

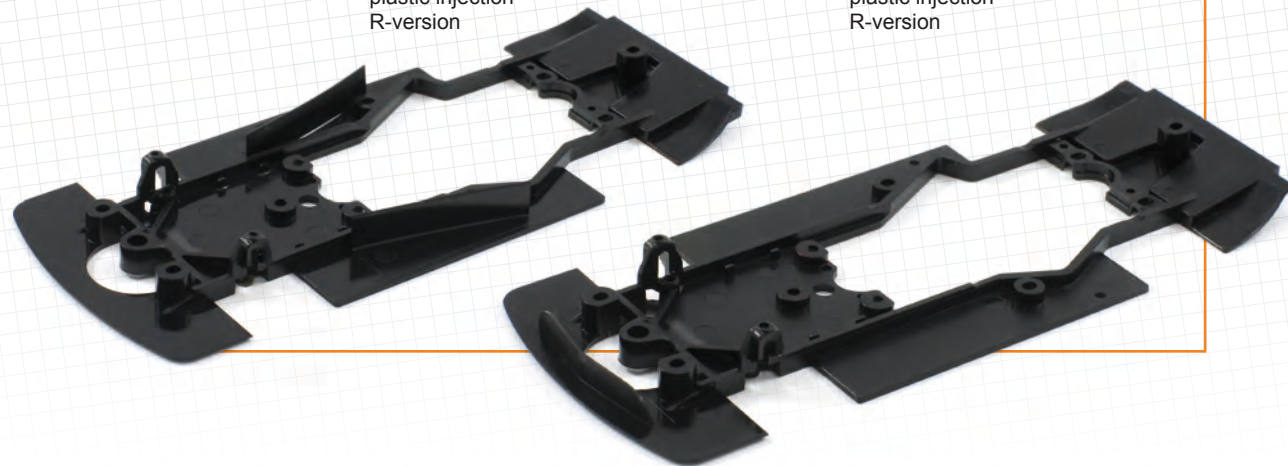



IBB | Auto
Racing

IBB Auto Racing S.L.

C/ La Masla, 26
08711 Odena (Igalada)
Barcelona - Spain
www.ibbautoracing.com
Tel. +34 938 030 880 Fax: +34 938 055 057



www.scaleauto-slot.com



www.facebook.com/ScaleautoSocial



twitter.com/ScaleautoSocial